

SERVICE MANUAL

SEEBURG

Wall-o-matic 3W-1

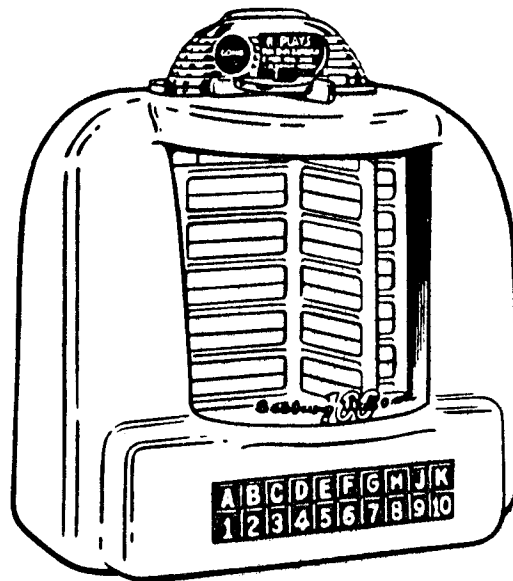

THE SEEBURG SALES CORPORATION
Chicago 22 Illinois

SEEBURG
WALL-O-MATIC
TYPE 3W-1

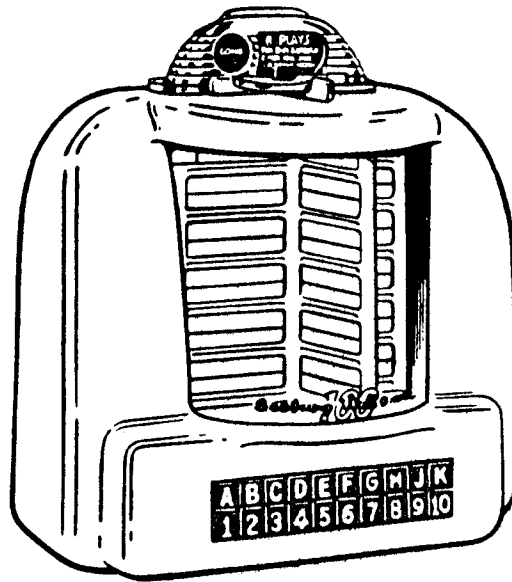

The Wall-O-Matic, Type 3W-1, is a unit of the SEEBURG WIRED REMOTE CONTROL SYSTEM for making selections from a point removed from the Select-O-Matic. It works in conjunction with the Selection Receiver in the Select-O-Matic to control

the Select-O-Matic Mechanism and effect the desired selection for the coin deposited. 5, 10, and 25c coins may be deposited establishing, respectively, 1, 2, or 6 selection credits.

INSTALLATION INSTRUCTIONS

To mount the Wall-O-Matic, first unlock it and remove the cover. There are three holes in the back plate for mounting. The upper two are slotted for fitting over screws already set in the wall at the proper points. The lower hole is for rigid mounting, by means of a screw, after the Wall-O-Matic has been hung in place.

If the mounting place on the wall is uneven, the Wall-O-Matic mounting plate should be shimmed with cardboard or wood before tightening the three mounting screws. Tightening these screws on an uneven wall will bend the mounting plate, may seriously effect the operation of the Wall-O-Matic, and will cause the cover and lock to bind.

After the Wall-O-Matics are mounted in their respective locations, the cabling can be installed. Use inter-connecting cable, Seeburg Part No. 12001, which can be purchased in lengths to suit requirements. At

the Select-O-Matic, cable plug, Seeburg Part No. 12015, is soldered to the end of the cable. Solder the blue wire to No. 1, the orange wire to No. 2, and the green wire to No. 3 of the plug. The plug fits into a 3-conductor socket in the Selection Receiver.

The plug and cable may be connected to from one to six wired Wall-O-Matics. The 3-conductor socket in the selection receiver will supply power for up to 6 Wall-O-Matics. If more than 6 are connected to the circuit, the transformer supplying power to the circuit may be burned out. If the installation requires more than 6 Wall-O-Matics an auxiliary power supply must be used for each additional circuit.

The terminal strip in the Wall-O-Matic is color coded in the same colors as the cable. Solder one lug to each of the cable wires (six soldering lugs are furnished with each Wall-O-Matic). Connect the blue wire of the

cable to the blue of the terminal strip, the orange wire to the orange of the terminal strip (ground) and the green wire to the green of the terminal strip. When the Wall-O-Matic is used as the junction to two cables, two conductors will be on each terminal.

The cash box can be removed from the right side of the Wall-O-Matic and is accessible only with the case removed.

The slug rejector is mounted on the coin drop slot. To remove the slug rejector for cleaning or service, lift up the drop slot casting slightly and lift out the program holder assembly. The slug rejector and the coin slot can then be lifted up and out of the Wall-O-Matic.

The slug return cup is located at the lower left side of the Wall-O-Matic. The slug ejector button is in front of the coin drop slot.

If a coin is deposited in the Wall-O-Matic when the main switch at the Phonograph is turned off, the coin will be lost and the customer cannot make a selection. If a coin is deposited and a selection is made immediately after the main switch is turned on, the tubes in the selection receiver will not be heated and the coin will be lost.

With the phonograph main switch turned on, a credit light, in the floor in front of the program holder of the Wall-O-Matic, goes on immediately after a coin is deposited in the coin slot. This light indicates that selections can be made. Only one coin at a

time should be deposited and selections made before an additional coin is inserted. The credit light stays on only as long as there remain unspent credits for the value of the coin deposited. Make one selection for a nickel, two selections for a ten cent piece and six selections for a twenty-five cent piece by pressing two buttons -- a lettered button and a numbered button -- for each selection.

The Wall-O-Matics are supplied with terminal brackets for open wiring installations. However, various types of conduit may be used in making installations. Terminal brackets are provided for the various types and can be obtained, under Seeburg Part Nos. as follows:

TYPE CONDUIT	SEEBURG PART NO.
#500 Wiremold	14083
#1900 Wiremold	14084
1/2" Metal Tubing	14085

A hole cover, Seeburg Part No. 14082, is available for closing the cable entry hole in the case if concealed wiring and the knock-out hole in the mounting plate is used for entry of the cables.

Bar Bracket Assembly, Seeburg Part No. 500185, is available for rigidly mounting the Wall-O-Matic on bars, counters and tables.

The Wall-O-Matic has been thoroughly tested before leaving the factory. Unless damaged in shipment, no adjustments should be necessary.

OPERATION

The 3W-1 Wall-O-Matic operates at 25 volts, AC 60 cycles. The power is supplied by the Selection Receiver or an auxiliary power supply in the Select-O-Matic through a 3-wire cable. Two of the three wires carry power to the lights and motor of the Wall-O-Matic. The other wire and one of the power circuit wires comprise a selection circuit to control the operation of the Selection Receiver.

Operation of the remote control system requires intermittent pulsing of the 2050

tube which is a part of the Selection Receiver in the Select-O-Matic. This is accomplished by the Wall-O-Matic when the grounded rotating switch blade (contact arm) passes over contacts which are connected to the tube through the selection switches and the 3-wire cable. Each time the switch blade passes over a connected contact the tube is pulsed.

The step switch and relay assembly in the Selection Receiver operates from the 2050 tube and connects a selector coil and a

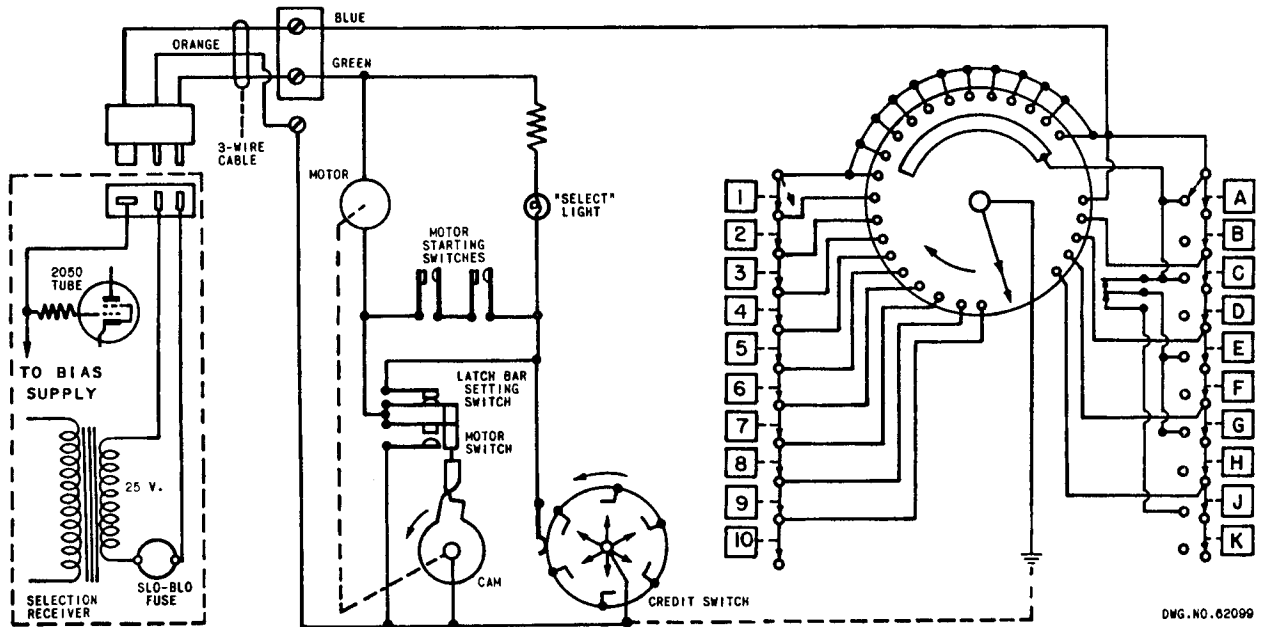

FIG. 2. SIMPLIFIED SCHEMATIC - 3W-1.

group solenoid of the Solenoid Assembly so they will be energized. This operation is dependent on the number of pulses and the intervals of time between them. Two series of pulses are required -- a first series for the selection of a selector coil circuit and a second series for selection of a group solenoid. The number of pulses in each series is determined by which Wall-O-Matic selection switches are pressed. There will be from 2 to 21 in the first series and from 1 to 5 in the second series. The rate of the pulses and the time interval between them is determined by the design of the Wall-O-Matic and the motor speed. This interval between individual pulses in both series is approximately 1/25 second and an interval of approximately 1/5 second occurs between the last pulse of the first series and the first pulse of the second series. A simplified circuit diagram of the connection of the selection circuit is shown in Figure 2.

The operating cycle of the Wall-O-Matic involves the motor, the selection switches, and the control switches for the motor. There are three positions or conditions for each cycle which are associated with these -- a Rest Position in which no credits are established, a Credit Position which is referred to the Wall-O-Matic after a credit is established but before the selection switches are pressed, and a Pulsing "Position" during which the motor operates and

the contact arm revolves to "ground" the contacts on the selector plate.

In the Rest Position, the selector Buttons are free to move in and out, the Latch Bar Setting Switch shown in Figures 2 and 4 is closed, and the Credit Switch is open. When a coin is deposited to establish credit, a coin switch is closed momentarily to energize a credit solenoid. The credit solenoid, in turn, operates a plunger which closes one of six snap-action switches on the credit switch assembly. The closed credit switch completes a circuit to the credit indicating light and, through the latch bar setting switch, to the motor. The credit light illuminates the "Select" escutcheon in front of and below the program holder. The motor, operating through a train of gears, turns a cam until the latch bar setting switch is caused to open by the latch bar lever dropping to the "credit step" of the cam. These positions of the cam and lever are shown in Figure 3.

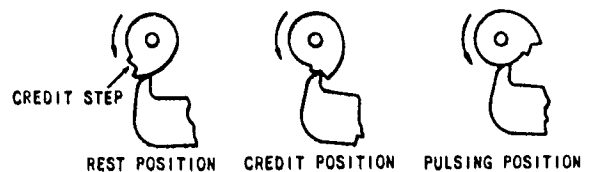

FIG. 3. CAM POSITIONS.

In the Credit Position of the cam, the motor is again at rest but the latch bar

lever has been changed to a position which has moved the selector switch latch bars so the selector buttons, when pressed, will remain in the pressed position.

On each of the selection switch assemblies -- the "letter switches" and the "number switches" -- is a Motor Starting Switch. The contacts of the motor starting switches are closed by a treadle bar which is actuated by a selection switch shaft when a selector button is pressed. The two switches are connected in series in the motor circuit so that, when a letter button and a number button are pressed, the motor again starts. The motor turns the cam so the latch bar lever drops from the credit step to the Pulsing "Position" as shown in Figure 3. In this position of the cam and lever, the latch bars are moved to a position which locks the selection switches in position -- pressed in or in normal position -- and the Motor Switch (Figures 2 and 4) is closed. This pulsing position prevails for almost a full turn of the cam. As the cam approaches its rest position, the latch bar lever is raised so the motor switch opens, the latch bar setting switch closes, and the latch bar lever moves the latch bars so the selector buttons are released to their normal positions.

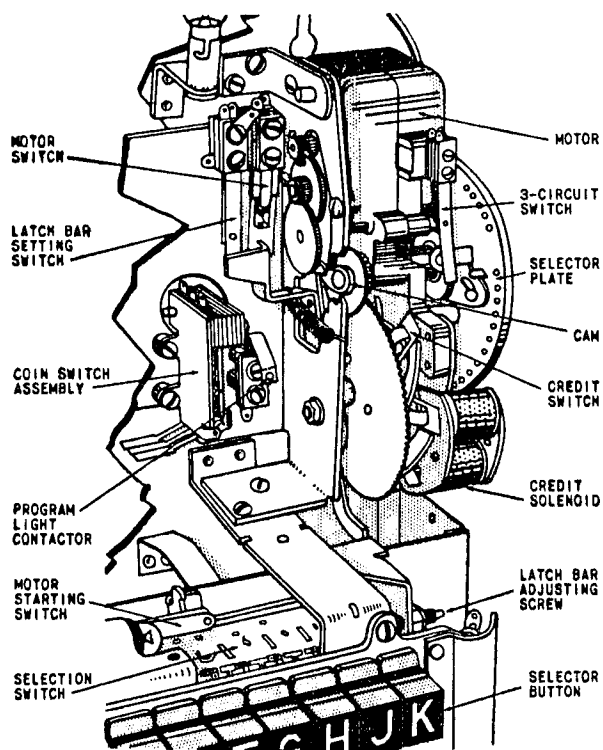

FIG. 4.

One of the functions of the motor is to turn the contact arm so it grounds the contacts on the selector plate. It is attached to the same shaft on which the cam is mounted and turns, with the cam, from the rest position to the credit position, through the pulsing "position", back to the rest position. In the rest and credit positions the end of the contact arm is between the first and last contacts on the plate. During rotation of the cam from the credit position to the rest position, the arm is in contact with and grounds momentarily and successively each of the contacts on the plate.

If a single credit is established by depositing a nickel at the beginning of the operating cycle, the credit switch will open and break the circuit through the motor starting switches before completion of the cam rotation to the rest position. Motor operation will be maintained by the circuit through the motor switch until the switch is opened by the cam as the rest position is attained. If more than a single credit is established by depositing a dime or a quarter at the beginning of the operating cycle, the credit switch will still be closed when the cam reaches the rest position and the motor circuit will again be closed through the latch bar setting switch until the credit position is attained. As the cam passes through the rest position, the selector buttons are released to their normal positions, the motor starting switches are opened, and the motor comes to a stop with the Wall-O-Matic in position for another selection to be made.

The motor switch referred to above and shown in Figure 4 is a snap-action switch in Wall-O-Matics below serial number 16646. The latch bar setting switches used in these Wall-O-Matics is a 2-blade spring leaf switch. In Wall-O-Matics above serial number 16645, the snap-action switch is replaced by the addition of another blade on the latch bar setting switch (making it a 3-blade switch) and a Motor Carry-over Segment on the selector plate as shown in Figure 11. The operation of the Wall-O-Matics with the motor carry-over segment differs only in that the motor switch opens before the rest position is attained by the cam (and contact arm) and the motor operation is maintained through the circuit formed by the

segment and the contact arm. The arm leaves the segment when the rest position is attained so, if no credits remain on the credit switch assembly, the motor stops in that position.

OPERATION OF CREDIT ASSEMBLY

The credit assembly, shown in Figure 5, includes six snap-action switches. The six switches are equally spaced around a credit switch which is keyed to a gear. The gear and switch are turned by the Wall-O-Matic motor one-sixth turn each time a selection is made. The snap-action switches are, therefore, advanced one position -- the distance between them -- for each selection made.

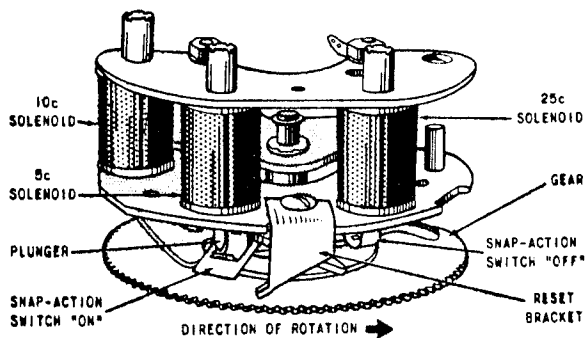

FIG. 5. CREDIT SOLENOID & SWITCH ASSEMBLY.

A reset bracket is mounted on the credit assembly frame. Each time a selection is made, the credit switch advances one position and one of the snap-action switches moves past the bracket. When a snap-action switch that has been turned "on" by a credit solenoid passes the bracket, it is engaged by the bracket and reset to the "off" position.

A "5c solenoid" is mounted so its plunger turns on a snap-action switch which is one position from the reset bracket. Because the switch will be reset and turned off with one operation of the Wall-O-Matic, one credit is set up when a 5c coin is deposited.

A "10c solenoid" turns on the snap-action switch which is two positions from the reset bracket allowing two selections to be made before the switch is reset.

A "25c solenoid" is six positions from the reset bracket and will turn on the snap-action switch which permits six selections to be made before it is reset.

Electrical connection to the credit switch is made to ground through the shaft on which the switch turns and through a collector ring and contact.

MAINTENANCE AND SERVICE

CLEANING

The slug rejector should be kept free of dirt and dust. If a rejector has been working successfully and becomes erratic or fails to work at all, the trouble can generally be attributed to dirt or to some stoppage in the coin track. Cleaning only should correct the trouble.

Switch and relay contacts should be cleaned with a contact burnisher. *Do not use a file, sandpaper, or emery cloth.*

The contacts on the selector disc should be cleaned with a cloth saturated with carbon-tetrachloride. *Do not use emery cloth or sandpaper.* The contacts are silver plated brass. To sand them or clean them with an abrasive will remove the plating and expose the brass. The brass does not provide good contact and will require more frequent service as well as cause erratic operation. The contacts should not be lubricated.

The contact point on the contact arm should be cleaned with carbon-tet'. It is not necessary to remove it from the shaft. A piece of cloth saturated with carbon-tet' can be drawn under the contact point.

The selector switches and the motor gears should be kept free of dirt and dust by blowing out. Do not use roach powders of any kind. Most of the powders are highly corrosive and will soon cause failure of the switches. If powders have been used, the switches should be thoroughly cleaned.

LUBRICATION

The motor gears should be lubricated with #105 Lubriplate. Shaft bearings should be oiled with SAE 10 oil.

A drop or two of SAE 10 oil on the motor bearings will reduce wear and friction to a minimum.

The scavenger linkage of the slug rejector can be sparingly lubricated with #105 Lubriplate at wear and friction points, but care should be taken so that it does not get into the coin track. Oil should not be used. The coin path of the rejector may be dusted with Motor Mica (see Section 9000 of #2 Service Manual).

MOTOR

The motor is designed to operate the Wall-O-Matic through a complete cycle in a little more than 2 seconds. If the motor is slow, the current impulses to the step relay (in the Selection Receiver) will be slow and cause erratic operation of the step switch assembly. The motor can best be checked for speed by allowing it to operate steadily and counting the turns per minute of the contact arm. Normal speed is 24 revolutions per minute. Acceptable speed limits are 21 to 26 rpm. If the motor is slow, check for binding or excessive friction. If the motor runs slow when there are no binds, it will have to be replaced.

COIN SWITCHES

Adjustment of the coin switches is shown in Figure 6 if erratic operation of the switches prevails, they should be cleaned with carbon-tet' or a contact burnisher and adjustments should be checked before resorting to bending the blades.

FIG. 6A. COIN SWITCH ADJUSTMENTS.

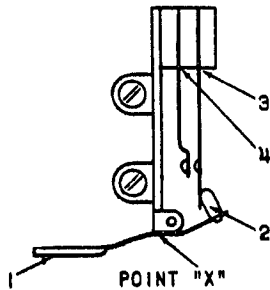

1. Adjust levers to be parallel to lower edge of slug rejector when bearing against switch bracket at Point "X".
2. Adjust the switch actuating cams to be tilted approximately as shown and overlap the blade approximately $3/32"$.

3. Bend long blade at this point for 4 to 5 grams tension toward cam as measured at switch contact point.
4. Bend short blade at this point so it moves approximately $1/64"$ when coin is slowly released from slug rejector.
Note: It is important that the ENDS of the bracer blades support the short contact blades as shown in Figure 6b.

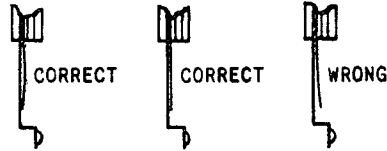

FIG. 6B. COIN SWITCH ADJUSTMENTS.

MOTOR SWITCH AND LATCH BAR SETTING SWITCH

Adjustment of the Snap-action Motor Switch used in Type 3W-1 Wall-O-Matics below serial number 16646 is made by positioning the switch assembly so the switch is open in the Rest and Credit Positions and closes in the Pulsing Position as shown in Figure 7. The switch is moved by loosening the two bracket mounting screws and sliding it up or down as required.

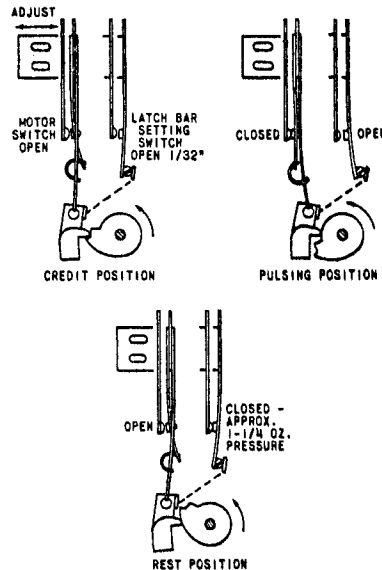

FIG. 7. MOTOR & LATCH BAR SETTING SWITCHES.

The Latch Bar Setting Switch is adjusted by bending the switch blades AFTER the Motor Switch adjustment has been made and checked.

LATCH BAR SETTING SWITCH

Adjustment of the Latch Bar Setting Switch used in Type 3W-1 Wall-O-Matics above serial number 16645 (with motor carry-over segment shown in Figure 11) is made as shown in Figure 8.

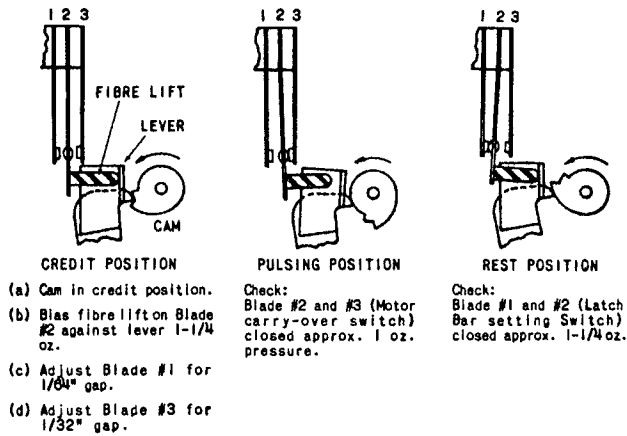

FIG. 8. LATCH BAR SETTING SWITCH.

CONTACT ARM POSITION

1. Turn the motor manually until the latch bar lever drops to the credit step of the cam then reverse the direction until the point of the lever is against the vertical part of the cam as shown in Figure 3.

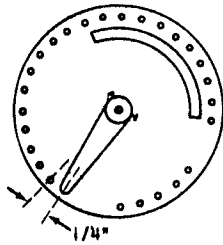

FIG. 9. CONTACT ARM POSITION.

- 2a. Type 3W-1 without motor carry-over segment (see Figure 11).

Set the Contact Arm on the shaft so the contact at the tip of the blade is approximately 1/4" from the first contact as shown in Figure 9 and the lower part of the hub is spaced approximately 1/8" from the surface of the selector plate as shown in Figure 10.

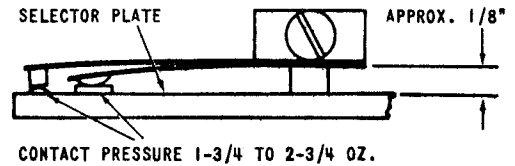

FIG. 10. CONTACT ARM.

- 2b. Type 3W-1 with motor carry-over segment (see Figure 11).

Set the Contact Arm on the shaft so the edge of the blade forms a "V" with the edge of the motor carry-over segment as shown in Figure 11 and the lower part of the hub is spaced approximately 1/8" from the surface of the selector plate as shown in Figure 10.

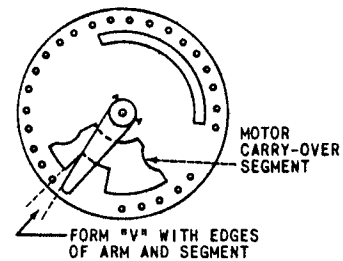
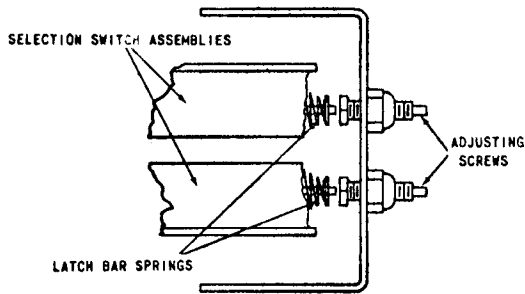

FIG. 11. CONTACT ARM POSITION WITH MOTOR CARRY-OVER SEGMENT.

LATCH BAR ADJUSTMENT

The selection switches have three conditions of operation corresponding to the three positions of the cam shown in Figure 3 and 4 and are operated by the cam through mechanical linkage. In the rest position, the switch latch bars are held against the pressure of the latch bar springs so the selector buttons are free to move in and out and will not stay in the pressed-in position. In the credit position the bars are released to a position which permits a selection switch, when pressed, to latch in the operated position but, if another switch is operated, the first will be released. In the pulsing position the latch bars are fully released so the selection switches are locked in either the normal or pressed positions.

The adjustment for the latch bar operation is made with two screws -- one for each selection switch assembly -- at the right of the assemblies (see Figures 4 and 12).



1. Place the cam in the Credit Position (Figure 3).
2. Turn the adjusting screws until the selection switch shafts strike the latch bars but do not latch in the pressed-in position.
3. Back out the screws 1/2 to 3/4 turn.
4. Check for positive locking of the switches when the cam is in the Pulsing Position.
5. Check for full release and free in-and-out movement of the switches when the cam is in the Rest Position.

FIG 12. LATCH BAR ADJUSTMENT.

RELAY ADJUSTMENT

The relay included in Type 3W-1 Wall-O-Matic below serial number 2303 interrupts the circuits paralleling the ladder circuit of the selection switch assembly with the lettered buttons. The relay is energized only during the time the contact arm is on the shorting segment of the selector plate. Adjustment of the relay is shown in Figure 13.

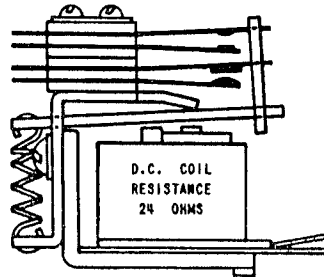

1. All Contacts normally open.
2. All Contact gaps 1/32".
3. All Contact pressures 1 oz.
4. Armature gap 1/16".

FIG. 13. RELAY ADJUSTMENT

3-CIRCUIT SWITCH ADJUSTMENT

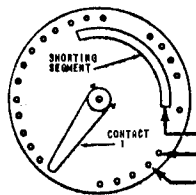

1. All Contacts closed and no pressure of lever against switch when Contact Arm is leaving shorting segment.
2. Contact begins to open when Contact Arm has reached 1st group Contact.
3. Contacts open 1/64" (minimum) when Contact Arm is on 2nd group Contact

FIGURE 14.

★ ★ ★

Wired Wall-O-Matic, Type 3W-1

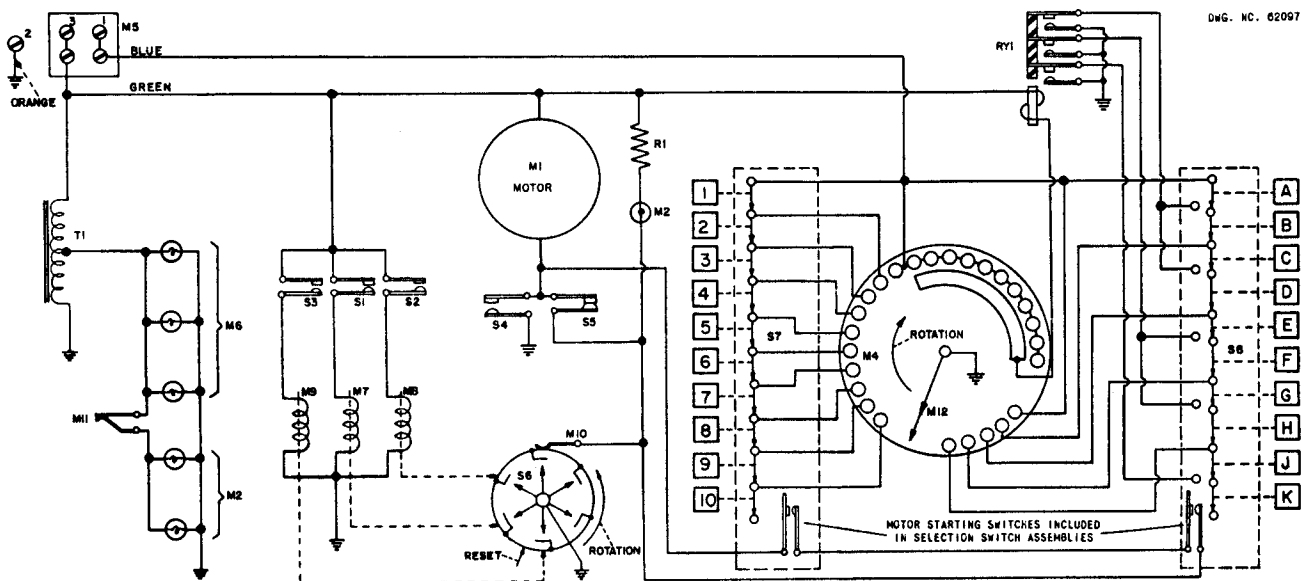

FIG. 15. SCHEMATIC DIAGRAM (BELOW SERIAL NO 2303)

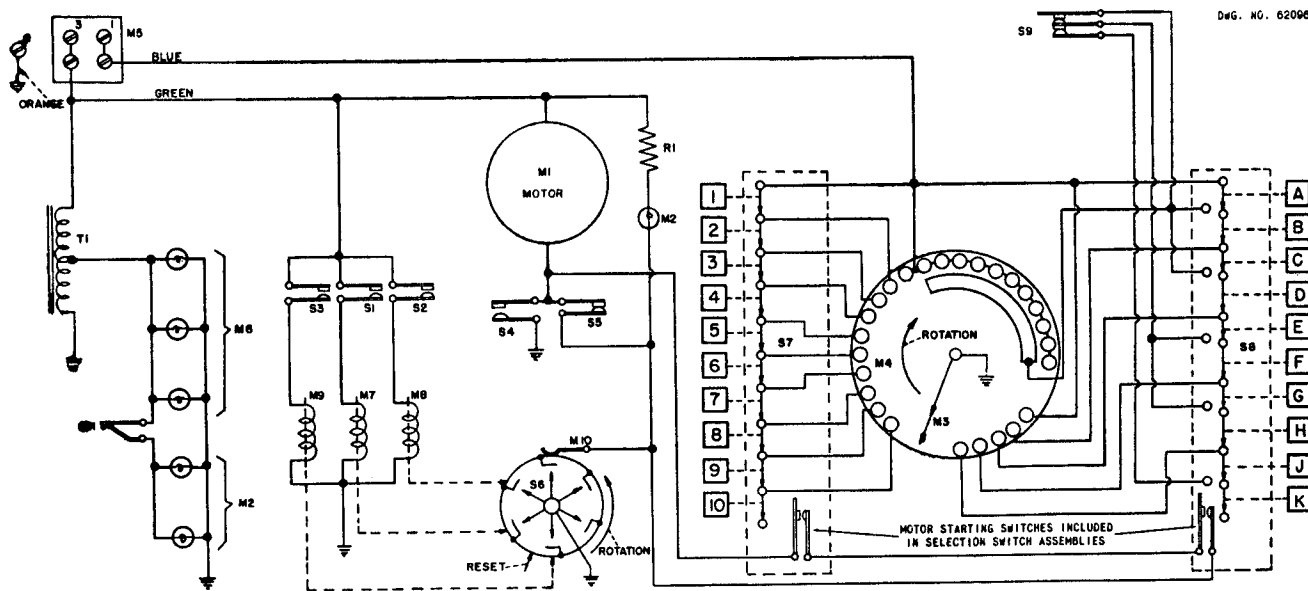
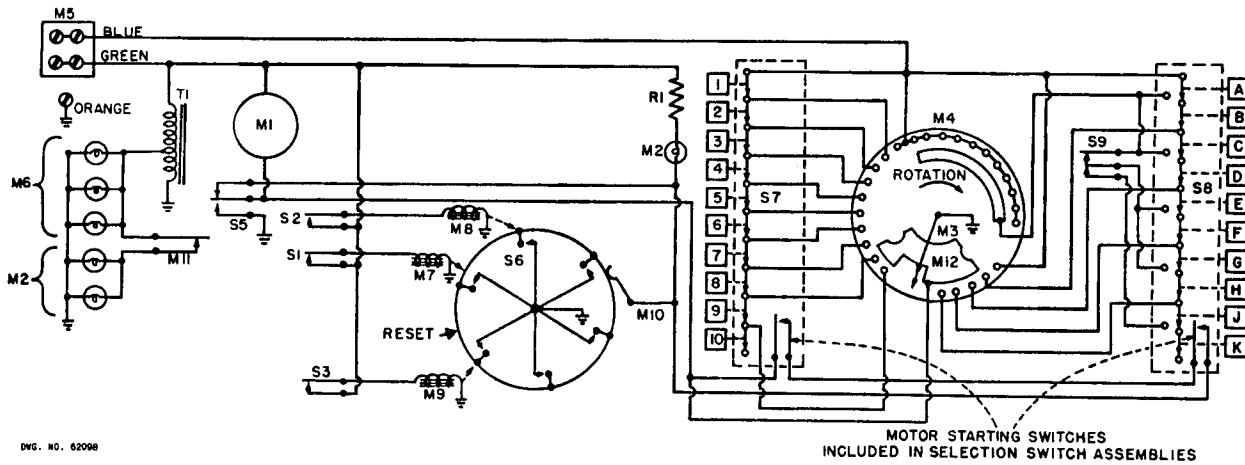

FIG. 16. SCHEMATIC DIAGRAM (SERIAL NO. 2303 TO 16646)

PARTS LIST

Item	Part No.	Description	Item	Part No.	Description	Item	Part No.	Description
M1	505013	Motor Assembly	M6	505173	Lamps Mazda #55	S1	504017	5c Coin Switch
M2	10242	Lamps Mazda #51	M7	505082	5c Solenoid Coil	S2		10c Coin Switch
M3	505109	Contact Wiper Arm	M8	505082	10c Solenoid Coil	S3		25c Coin Switch
M3	505217	Contact Wiper Arm Used only with Wall- O-Matic Relay RY1 see Figure 15	M9	505082	25c Solenoid Coil	S4	505090	Carry-over Switch
M4	505103	Selector Plate Assembly	M10	505070	Brush Assembly	S5	505101	Latch Bar Setting Switch
M5	13398	Terminal Strip	M11	504045	Contact Assembly	S6	504140	Credit Switch
			R1	81126	100 Ohm Res., 5 Watt	S7	505108	Selector Switch, Bottom
			RY1	250996	Relay	S8	505107	Selector Switch, Top
						S9	505190	Three Circuit Switch
						T1	501012	Lighting Transformer

Wired Wall-O-Matic, Type 3W-1



DWG. NO. 62098

FIG. 17. SCHEMATIC DIAGRAM (ABOVE SERIAL No. 16645)

PARTS LIST

Item	Part No.	Description	Item	Part No.	Description	
M1	505013	Motor Assembly	M10	505070	Brush Assembly	
M2	10242	Lamps Mazda #51	M11	504045	Contact Assembly	
M3	505109	Contact Wiper Arm	R1	81126	100 Ohm Resistor, 5 Watt	
M3	505217	Contact Wiper Arm Used only with Wall- O-Matic Relay RY1 see Figure 15	RY1	250996	Relay	
M4	505103	Selector Plate Assembly	S1 } S2 } S3 }	504017	5c Coin Switch 10c Coin Switch 25c Coin Switch	
M5	13398	Terminal Strip	S4		505090	Carry-over Switch
M6	505173	Lamps Mazda #55	S5		505220	Latch Bar Setting Switch
M7	505082	5c Solenoid Coil	S6	504140	Credit Switch	
M8	505082	10c Solenoid Coil	S7	505108	Selector Switch, Bottom	
M9	505082	25c Solenoid Coil	S8	505107	Selector Switch, Top	
			S9	505190	Three Circuit Switch	
			T1	501012	Lighting Transformer	

Wired Wall-O-Matic, Type 3W-1

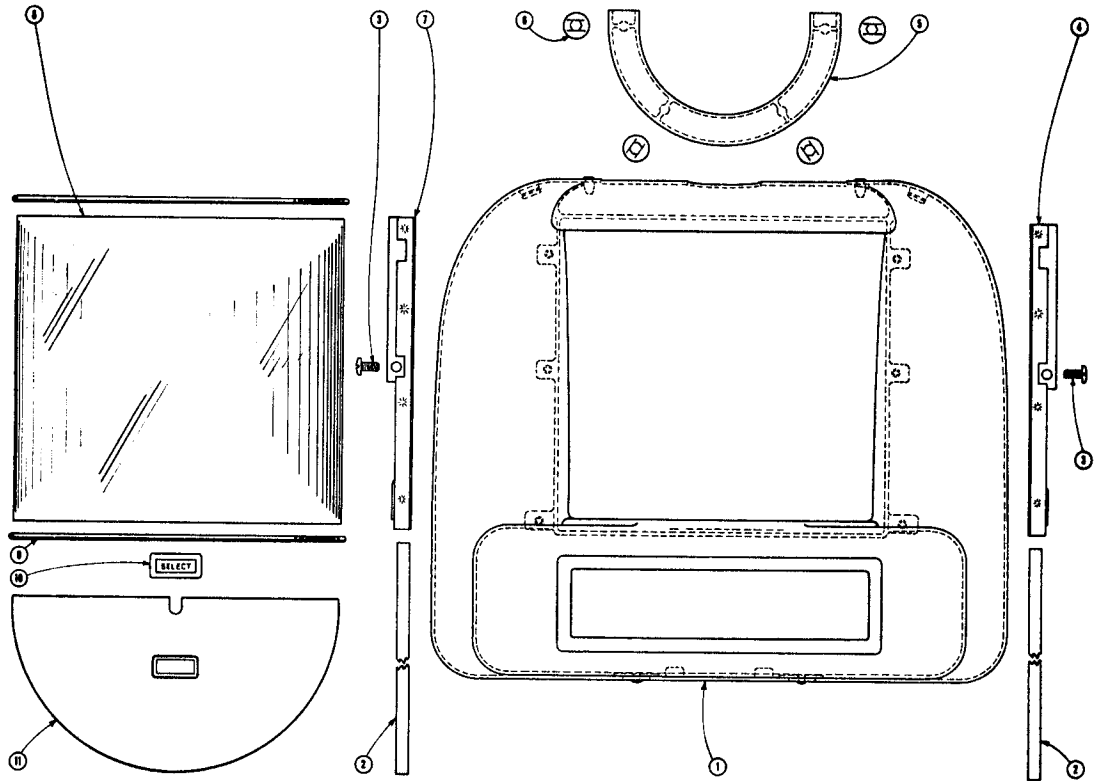

FIG. 18. HOUSING ASSEMBLY

Item	Part No.	Description
	505231	Housing Complete with #505230 Housing and all listed parts
1	505229	Housing, only, Chrome with holes for ring, Item 5
	505230	Housing, only, Chrome without holes for ring, Item 5
2	505175	Program Window Retainer Gasket
3	71034	8-32 x 3/8 B.H. Machine Screw
4	505154	Window Retainer Strip & Baffle Assem., L.H.
5	505204	Drop Slot Guard Ring
6	70113	Speed Nut
7	505153	Window Retainer Strip & Baffle Assem., R.H.
8	505030	Program Window
9	505174	Program Glass Gasket
10	504097	Selection Window
11	505160	Name Plate

Wired Wall-O-Matic, Type 3W-1

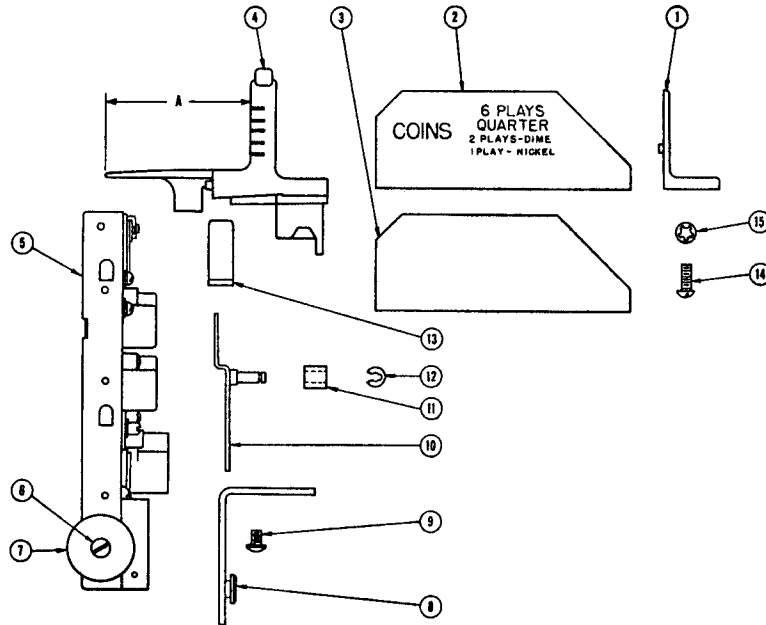

FIG. 19. COIN EQUIPMENT

Item	Part No.	Description
1	505024	Drop Slot Back
2	505118	Instruction Window
3	505119	Window Backing
4	505203	Drop Slot Front
5	505177	Slug Rejector
6	71464	8-32 x 1/4 B H Machine Screw
7	72237	Flat Washer
8	504064	Guide Bracket Assembly
9	71464	8-32 x 1/4 B H Machine Screw
10	504066	Ejector Arm & Stud Assembly
11	504068	Ejector Arm Roller
12	S22021	"C" Washer
13	504069	Push Button
14	71081	8-32 x 7/16 R H Machine Screw
15	73082	Lock Washer

Wired Wall-O-Matic, Type 3W-1

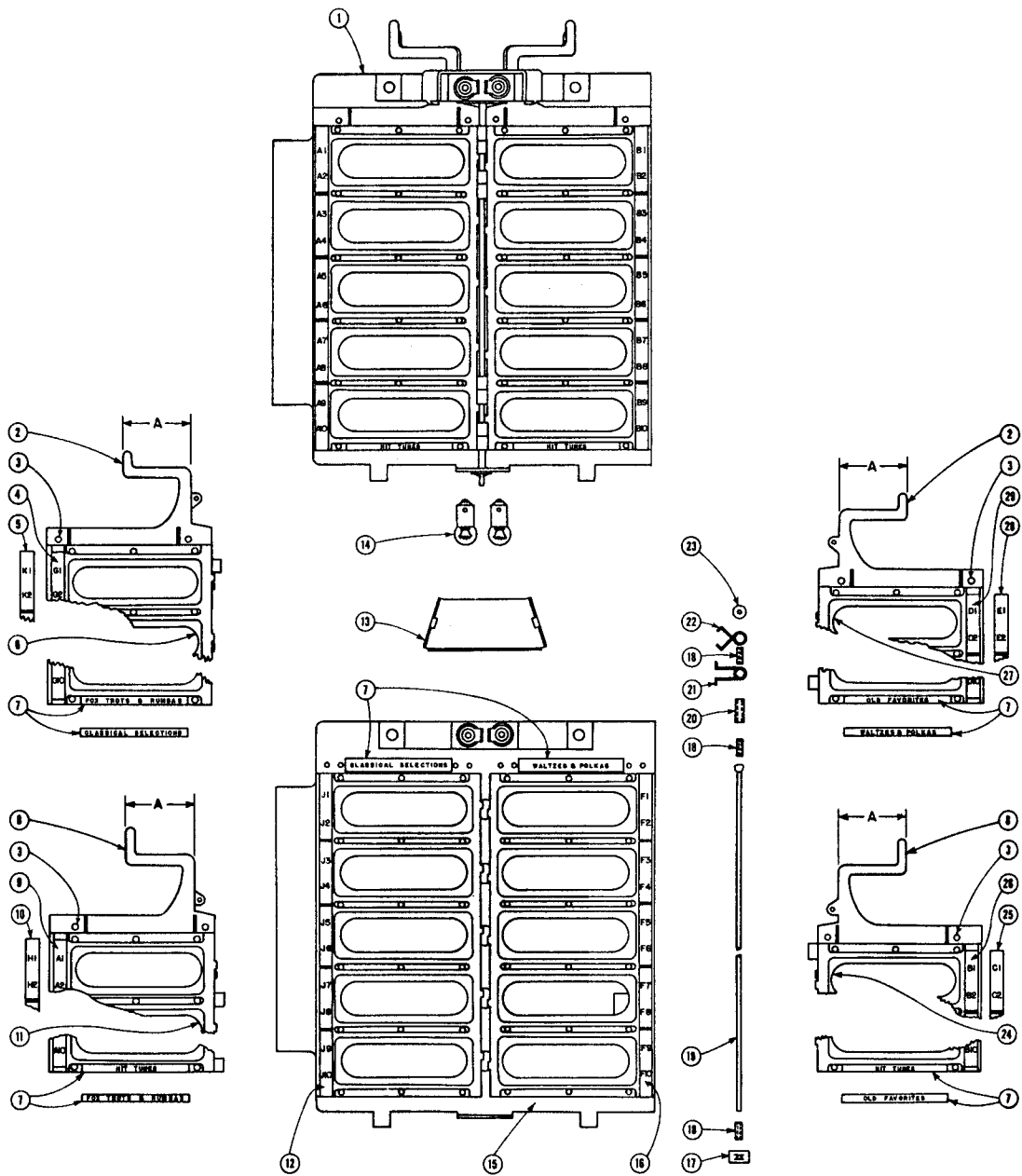

FIG. 20. PROGRAM HOLDER ASSEMBLY

Item	Part No.	Description	Item	Part No.	Description
1	505206	Program Holder Assembly, complete	15	505017	Program Title Strip Retainer
2	505026	Program Leaf Handle	16	505096	Number Strip (F1 to F10)
3	505201	Program Leaf Handle	17	70149	Tinnerman Nut
4	79029	Rivet .088 x 5/32"	18	505144	Spacer (Short)
5	505097	Number Strip (G1 to G10)	19	505143	Leaf Hinge Rod
6	505100	Number Strip (K1 to K10)	20	505145	Spacer (Long)
7	505207	Program Holder Leaf (K & G), complete	21	505199	Hinge Spring
8	505171	Classification Labels	22	505146	Hinge Spring
9	505025	Program Leaf Handle, Long	23	72246	1/4 x .078 x .020 Flat Washer
10	505202	Program Leaf Handle, Long	24	505209	Program Holder Leaf (B & C), complete
11	505091	Number Strip (A1 to A10)	25	505093	Number Strip (C1 to C10)
12	505098	Number Strip (H1 to H10)	26	505092	Number Strip (B1 to B10)
13	505208	Program Holder Leaf (H & A), complete	27	505210	Program Holder Leaf (D & E), complete
14	505099	Number Strip (J1 to J10)	28	505095	Number Strip (E1 to E10)
15	505183	Program Light Shield	29	505094	Number Strip (D1 to D10)
16	10242	#51 Lamp			

Wired Wall-O-Matic, Type 3W-1

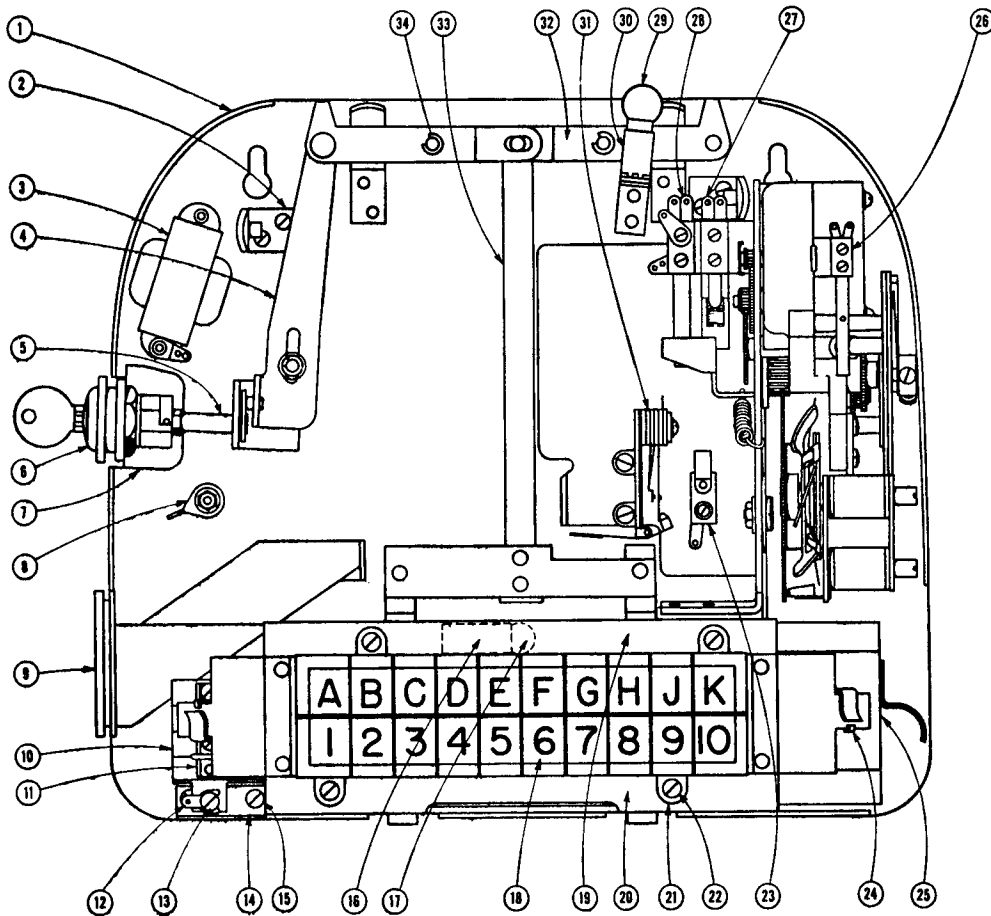

FIG. 21. BACK PLATE

Item	Part No.	Description	Item	Part No.	Description
1	505055	Back Plate Assembly	19	505184	Shield (Upper)
2	505062	Program Holder Mtg. Bracket Assem.	20	505191	Shield (Lower)
3	501012	Transformer	21	505172	Button Lighting Plate Assem.
4	505113	Lock Pawl Assem.	22	71482	6-32 x 1/4 B H Machine Screw
5	505110	Lock Shaft Disc & Stud Assem.	23	504045	Brush Assembly
6	14042	Lock Assembly	24	505121	Light Socket Assembly (#55 Lamp #505173)
7	14031	Lock Mtg. Bracket	25	505147	Coin Box Assembly
8	81126	100 ohm 5% 5 w. Resistor	26	505190	Three Circuit Switch
9	505050	Slug Return Chute	27	505090	Carry-over Sw. & Bracket Assem. Used below Ser. #16646
10	501044	Insulation - A.C. Terminal	28	505101	Latch Bar Setting Switch
11	13398	Terminal Strip	29	505173	#55 Mazda Lamp
12	74078	Spade Solder Lug	30	505066	Lamp Socket Assembly
13	71466	6-32 x 3/16 B H Machine Screw	31	504017	Coin Switch
14	14104	Bottom Hole Cover	32	505040	Lock Pawl (Upper)
15	71483	6-32 x 1/8 B H Machine Screw	33	505115	Lower Lock Bar Assembly
16	505122	Light Socket Assembly	34	J22021	"C" Washer
17	10242	#51 Mazda Lamp			
18	505011	Push Button			

Wired Wall-O-Matic, Type 3W-1

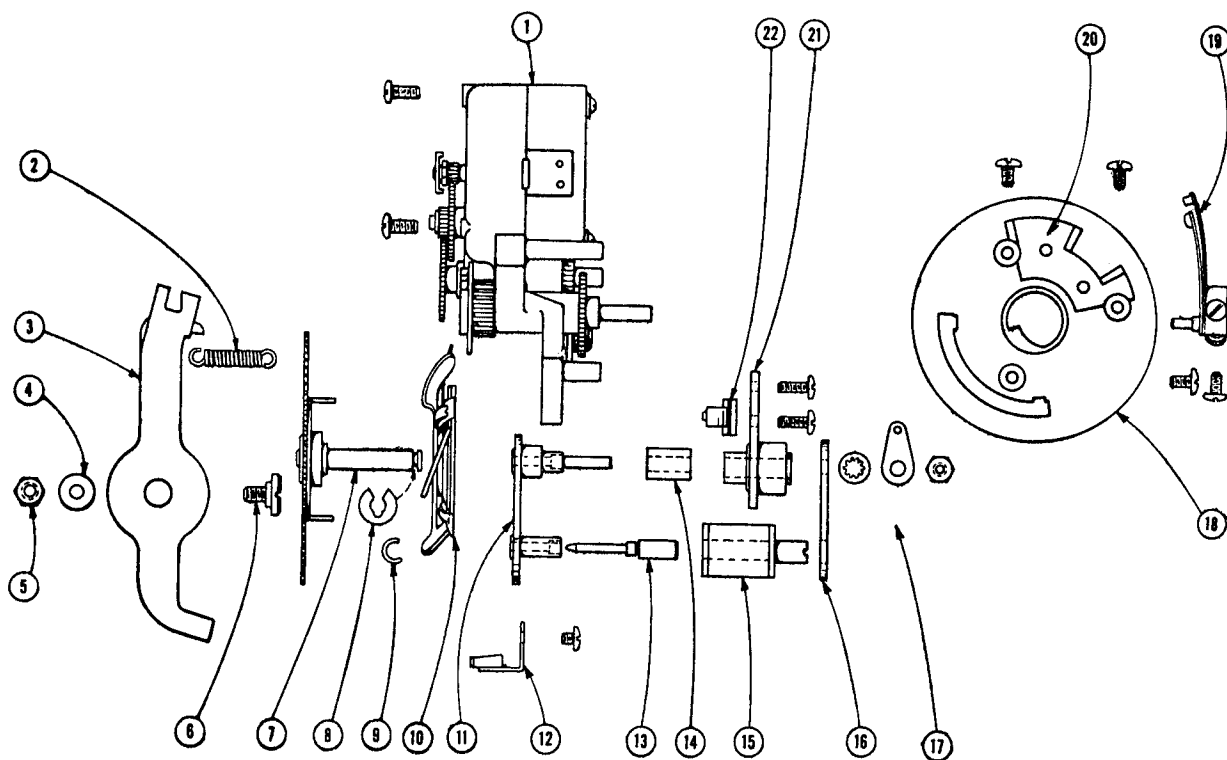

FIG. 22. MOTOR, CREDIT & CONTACT ASSEMBLY

Item	Part No.	Description
1	505013	Motor Assembly
2	400161	Spring
3	505065	Latch Bar Pawl & Sw. Op. Lever Assem.
4	73089	#1210 Shakeproof Lock Washer
5	70003	10-32 Hex. Nut
6	505178	Shoulder Screw
7	504164	Gear Bracket & Shaft Assembly
8	H20065	"C" Washer
9	504142	Spring
10	504140	Credit Switch
11	505155	Plate & Stud Assembly
12	504150	Re-set Bracket
13	505083	Solenoid Plunger Assembly
14	505086	Bushing
15	505082	Solenoid Coil Assembly
16	504148	Coil Mtg. Plate - Upper
17	73082	Shakeproof
	74106	Solder Lug
	70001	Hex Nut
18	505103	Selector Plate Assembly
19	505109	Contact Wiper Arm Assem.
20	505197	Carry-over Segment
21	505068	Bearing & Mtg. Bracket Assem.
22	505070	Brush Assembly

Seeburg
WALL-O-MATIC "100"
Type 3W1-D

The Wall-O-Matic "100", Type 3W1-D is the same in general appearance and size as the Type 3W1. The operation is the same except that the 3W1-D is arranged for three plays for a 25-cent coin and one play for either a dime or two nickels. The difference between the 3W1-D and the 3W1 is in the information on the coin instruction window and the name plate below the program leaves, in the slug rejector nickel coin switch and the connections to the coin switches, and the credit assembly. All of the service manual data for the Type 3W1, pages 12041 to 12055, applies equally well to the Type 3W1-D except the description of the operation of the credit assembly, the diagram on page 12050 and some of the parts lists.

The coin instruction window reads "3 plays - Quarter" - "1 play-dime or 2 nickels".

The name plate below the program leaves is the same in both types except for the type number of the respective unit.

The operation of the credit assembly of the Type 3W1, as discussed on page 12045, details operation for 5, 10, and 25-cent coins for, respectively, 1, 2, and 6 selections. The credit assembly of the 3W1-D uses a different position for the reset bracket; the credit solenoid in the 3-credit position is connected to and operated by the 25-cent coin switch; the credit solenoid in the 1-credit position is connected to and operated by the dime and nickel coin switch. The "5-cent solenoid" is not used. It is not connected to a coin switch and has both connecting leads grounded. The connections of the solenoids and coin switches are detailed in the complete diagram on page 12058.

The slug rejector is designed to accept quarters, dimes and nickels. Each quarter and dime operates, respectively, a quarter and dime coin switch but only alternate nickels operate the associated nickel coin switch. This is accomplished with a nickel diverter that is incorporated in the slug rejector. The operation of the diverter and the paths of the nickels are shown in Figure 1 where it can be seen that the first of two coins is diverted from the coin switch. The coin passes into the cash box but tilts the diverter so the second nickel operates the coin switch as it drops from the rejector. In this manner the 5-cent coin switch will be closed only once for two nickels, and, because this switch and the dime switch are both connected to the credit solenoid in the 1-credit position, a single credit will be set up for 10 cents whether it be a single 10-cent coin or two nickels.

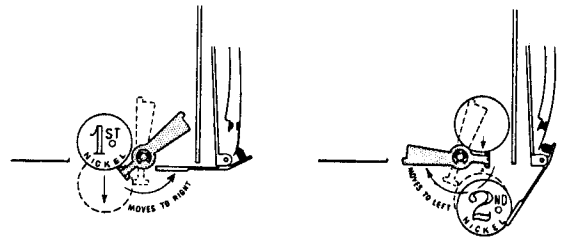

Figure 1. Nickel Diverter

- (a) If the slug rejector without the nickel diverter, (As used in the Type 3W1 Wall-O-Matic), is used in the Type 3W1-D Wall-O-Matic, it is necessary that the path of the nickels through the rejector be obstructed so that the 5-cent coins will be rejected. If this is not done, a single credit will be established in the Credit & Cancel Unit for each nickel that passes into the cash box.
- (b) The coin switch assembly in the 3W1 and 3W1-D are similar but the actuator of the nickel coin switch is $5/32$ " shorter when associated with a slug rejector equipped with the nickel diverter.

WALL-O-MATIC "100", TYPE 3W1-D

The Parts Lists for 3W1, pages 12051 to 12055, apply to the 3W1-D except as follows:

PARTS LIST

Page	Item	Part Name	Part No.
12051	-	Housing Complete	505346
	11	Name Plate	505347
12052	2	Instruction Window	505345
	5	Slug Rejector	505302
12054	1	Back Plate Assembly	505340
	31	Coin Switch	505343
12055	1	Motor Assembly	505281

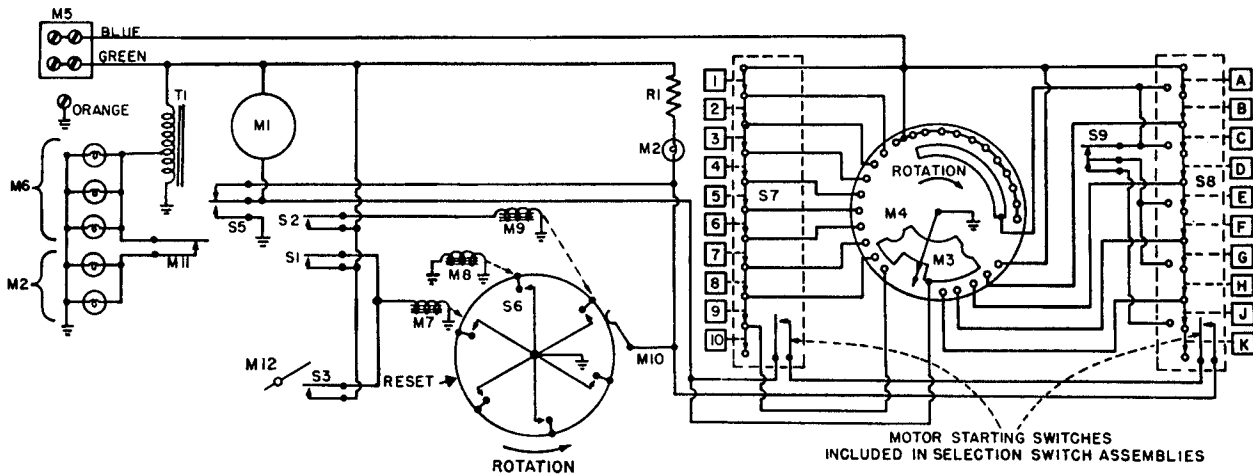

Figure 2. Schematic Diagram

PARTS LIST

Item	Part No.	Part Name	Item	Part No.	Part Name
M1	505281	Motor Assembly	M12		Nickel Diverter
M2	10242	Lamps - Mazda No. 51	R1	81126	100 Ohm Resistor - 5 Watt, 5%
M3	505109	Contact Wiper Arm	S1		5¢ Coin Switch 10¢ Coin Switch 25¢ Coin Switch
M4	505103	Selector Plate Assembly	S2	505343	
M5	13398	Terminal Strip	S3		
M6	505173	Lamps - Mazda No. 55	S5	505220	Latch Bar Setting Switch Assembly
M7	505082	10¢ Solenoid Coil	S6	504140	Credit Switch
M8	505082	- Solenoid Coil	S7	505108	Selector Switch - Bottom
M9	505082	25¢ Solenoid Coil	S8	505107	Selector Switch - Top
M10	505070	Brush Assembly	S9	505190	Three Circuit Switch
M11	504045	Contact Assembly	T1	501012	Power Transformer

5—10—25c SLUG REJECTOR

THEORY OF OPERATION

When a piece of metal that is an electrical conductor is passed through a magnetic field, a small voltage is generated within the metal. The voltage thus generated, short-circuited within the body of the metal, causes currents to flow in it. These currents set up magnetic forces in opposition to the magnetic field. The opposing fields tend to resist the force which drives the metal.

Since various metals have different degrees of electrical conductivity, it is possible to detect one metal from another by noting the behavior of each in the magnetic field.

The speed of a metal coin rolling or falling through a magnetic field will be governed by the electrical conductivity of the metal. This is the basic principle used in the detection of coins in the 5 — 10 — 25c slug rejector.

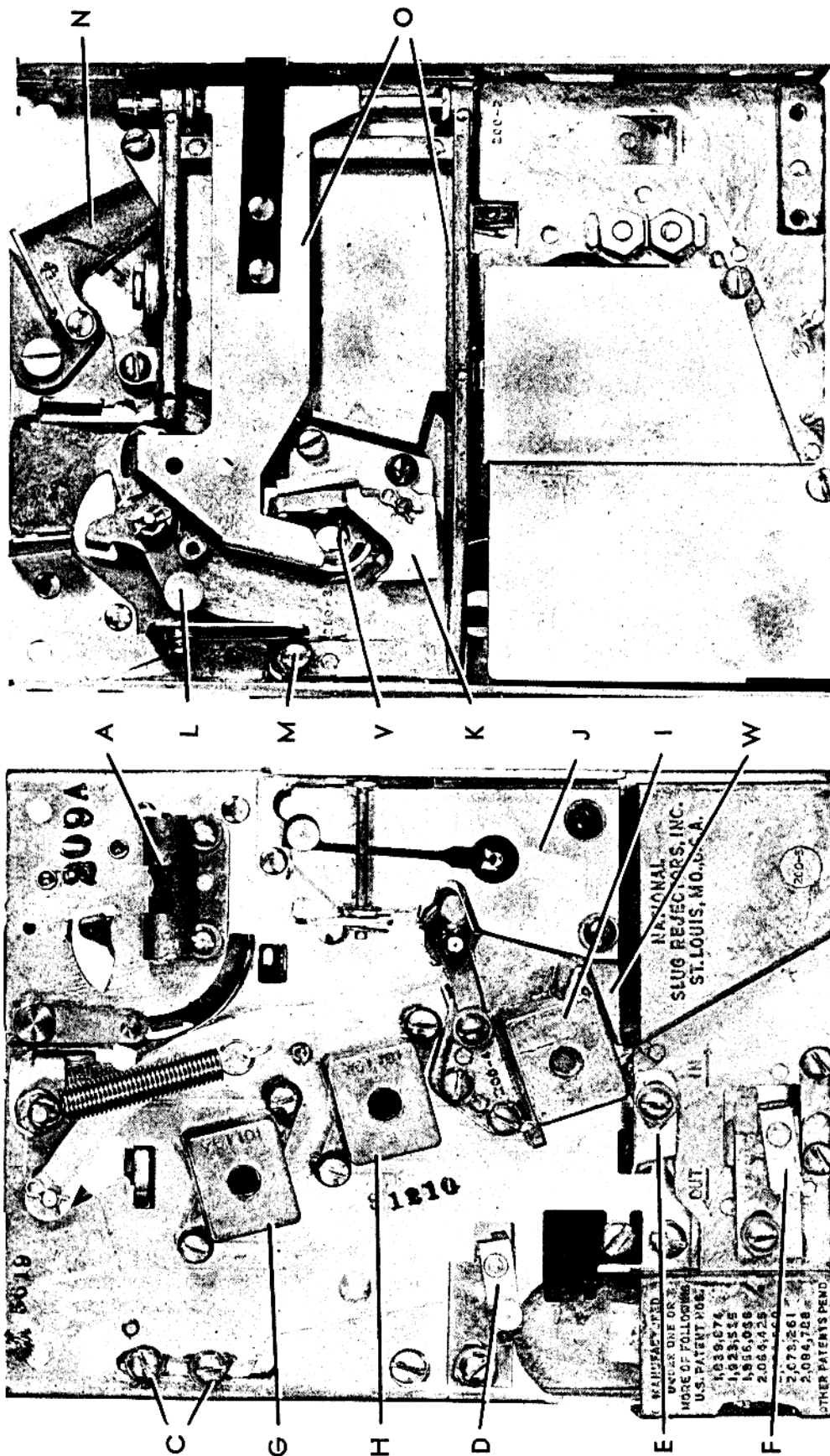

FIG. 1

LEVELING

IT IS ABSOLUTELY NECESSARY THAT THE SLUG REJECTOR BE LEVEL. The spirit level, (A), is provided for indicating the position of the rejector.

SERVICE NOTES

It is recommended that the magnets never be removed unless absolutely necessary. If they are removed, they should be handled with care and a soft iron "keeper" should be placed across the pole faces.

The 10c scavenger gate, (J), has an adjusting screw, (M), which is set to allow the gate to just close. If the screw is not far enough in, the gate will not close. If the screw is too far in, the rear scavenger gates, (O), will be held open.

The 5c undersize gauge, (K), must work freely at all times. If any adjustment is made, the unit should be tested with dimes as well as nickels since the undersize gauge wire, (V), on this gauge, also serves to deflect dimes into the proper path.

The rotary quarter sizer, (L), has no adjustment but should work freely at all times, turning easily with the weight of the quarter.

The scavenger wiper blade, (N), is effected by the adjustment of the deflector, (C), for fast moving 25c size slugs. It is important that this part move freely and returns to its normal position after the scavenger is released.

Use no lubricants.

KEEP THE REJECTOR CLEAN AND LEVEL. If it is necessary to dismantle the rejector for cleaning, be sure to replace washers under the screw heads so the screws will not protrude into the path of a coin.

Adjustments of the slug rejector are given in Figures 2 to 9, inclusive. These illustrations also show the paths of coins and slugs through the rejector. Before making any adjustments, study the illustrations so the reason for the adjustment is fully understood. Guess work and "cut and try" is seldom successful and usually results in unsatisfactory operation.

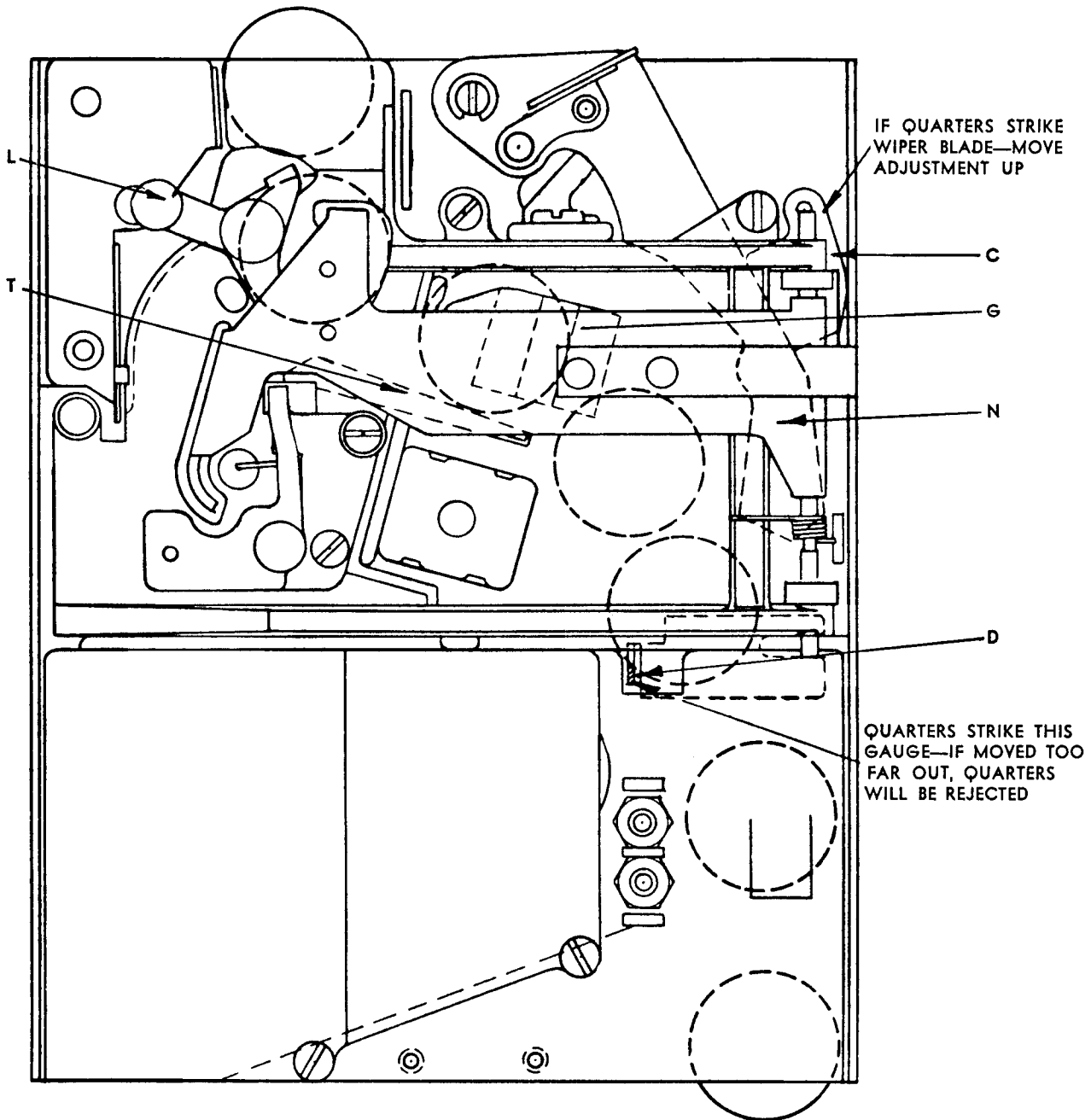

FIG. 2—PATH OF 25c COIN

Fig. 2 shows the path of a genuine 25 cent coin. The coin first drops in the arms of the rotary sizing gauge (Item L) which turns under the weight of a good coin and deposits it upon inclined rail (Item T). As the coin rolls down the rail past the 25c magnet (Item G) its speed is

checked (by generated currents) and it leaves the rail at an angle that will permit it to miss the brass deflector (wiper blade) (Item N) and land with its center of gravity to the right of the copper deflector (Item D), thus it is accepted.

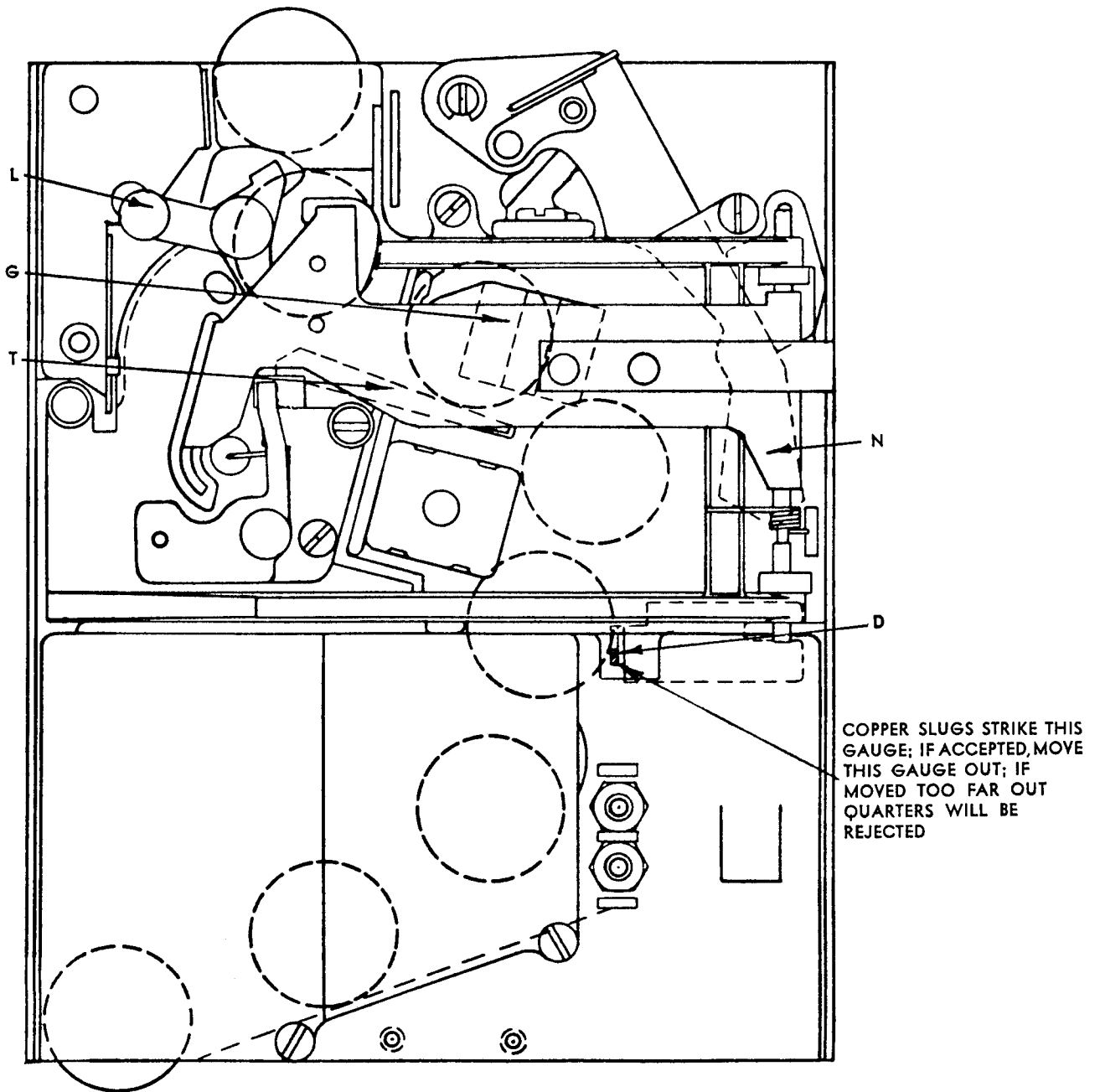

FIG. 3—PATH OF 25c SIZE COPPER SLUGS

A 25c size slug of copper follows the same path as the quarter until it reaches the magnet (Item G). Since copper is a very good electrical conductor, currents of a rather high order are

generated. The copper slug will drop almost straight down at the end of the rail and strike the copper deflector (Item D) with its center of gravity to the left.

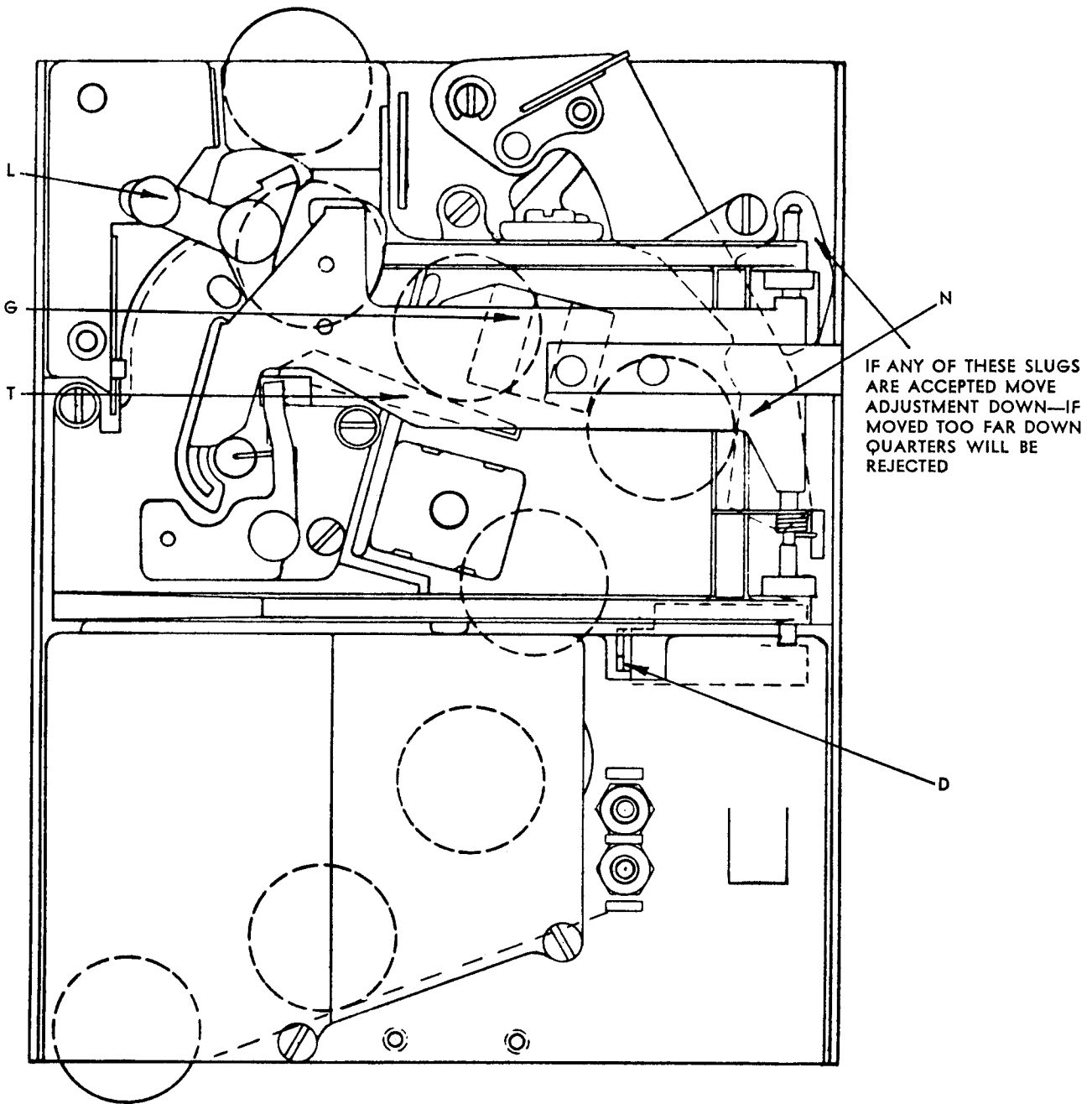

FIG. 4—PATH OF 25c SIZE BRASS, LEAD, ZINC, OR GERMAN SILVER SLUGS

25c size slugs of brass, lead, zinc or German silver have a higher electrical resistance than a quarter and as a result go through the magnetic field at a greater speed. This raises the angle in

which they leave the rail to a point where they strike the brass deflector (wiper blade) (Item N) and are deflected to the left of the copper gauge (Item D).

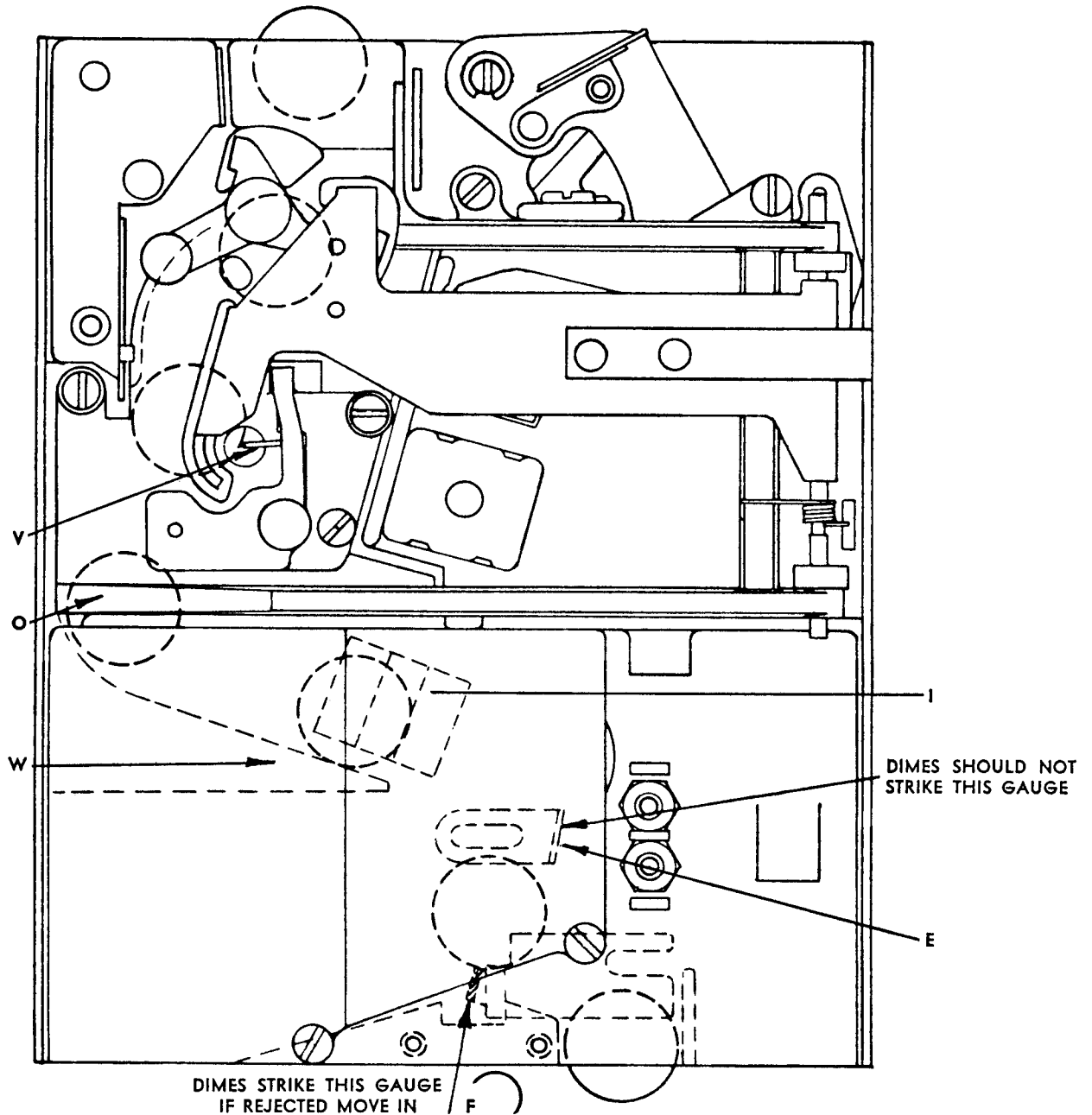
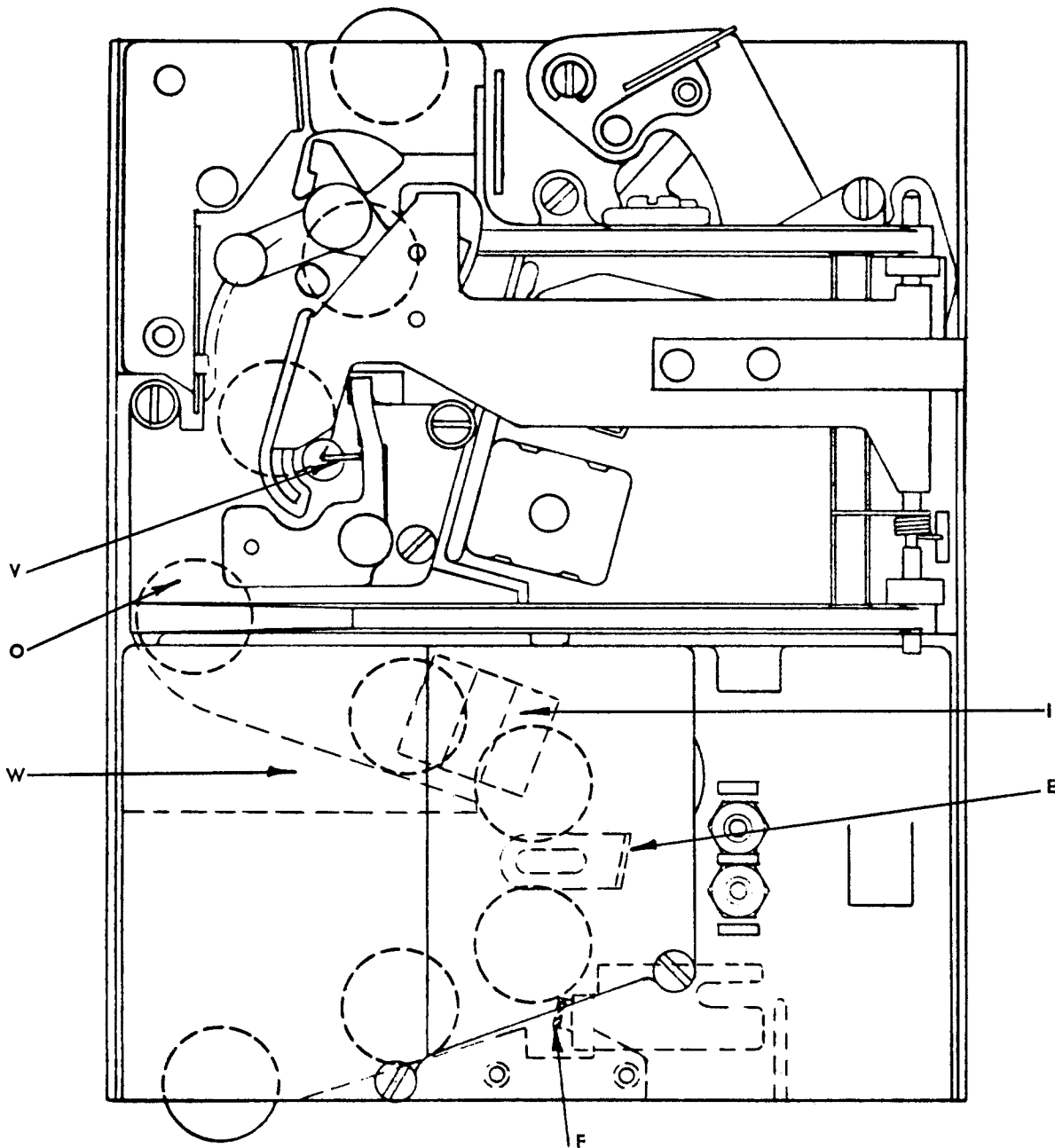

FIG. 5—PATH OF 10c COIN

As a 10c size coin enters the slug rejector it passes through the 25c rotary gauge and to the left of the 5c undersize gauge wire (Item V) (oversize 10c slugs stop here). At the bottom edge of the scavenger gate (Item O) the dime is deflected through an opening in the frame plate of the unit and is deposited on the 10c rail (Item W) which is mounted on the bottom edge of the

10c scavenger gate (undersize slugs are rejected here) if the coin is of the correct size it rolls down the 10c rail (Item W), passing through the field of magnet (Item I) where its speed is retarded enough to prevent it from striking brass deflector (Item E) and will land on copper deflector (Item F) with its center of gravity to the right.



COPPER SLUGS STRIKE THIS GAUGE—IF ACCEPTED MOVE GAUGE OUT
IF MOVED TOO FAR OUT DIMES WILL BE REJECTED

FIG. 6—PATH OF 10c SIZE COPPER SLUGS

10c size slugs of copper follow the path of the dime to the magnet where it is retarded more than a dime due to the higher conductivity of copper.

The copper slug as a result drops off the rail onto the copper deflector gauge (Item F) with its center of gravity to the left.

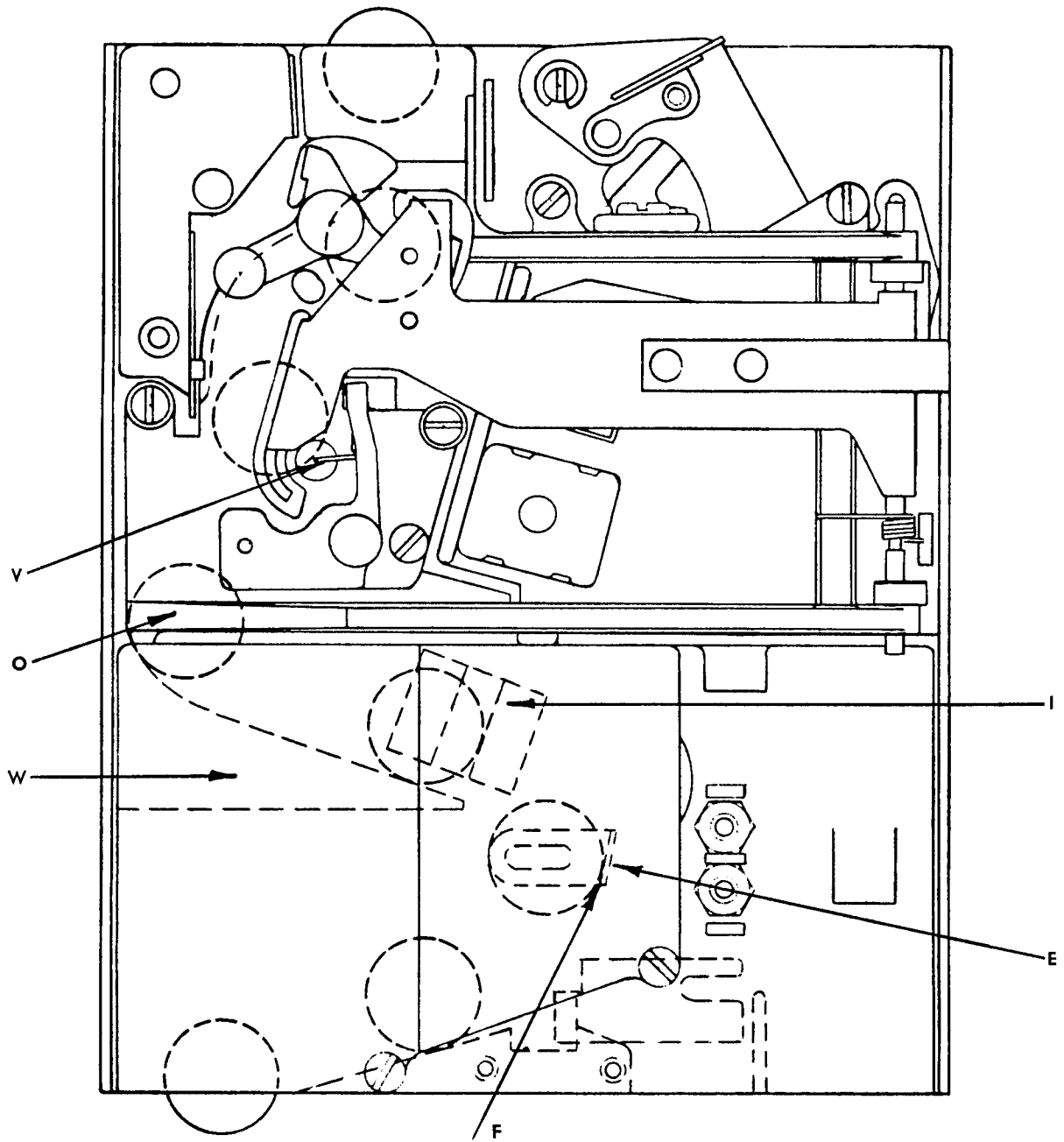

THESE SLUGS MUST STRIKE THIS GAUGE TO BE REJECTED

FIG. 7—PATH OF 10c SIZE LEAD, ZINC, BRASS, OR GERMAN SILVER SLUGS

10c size slugs of brass, lead, zinc or German silver also pass the magnet (Item I) via the route of a good 10c coin, here again the spurious coins

having a higher electrical resistance will leave the rail (Item W) at a higher rate of speed and strike the brass deflector (Item E).

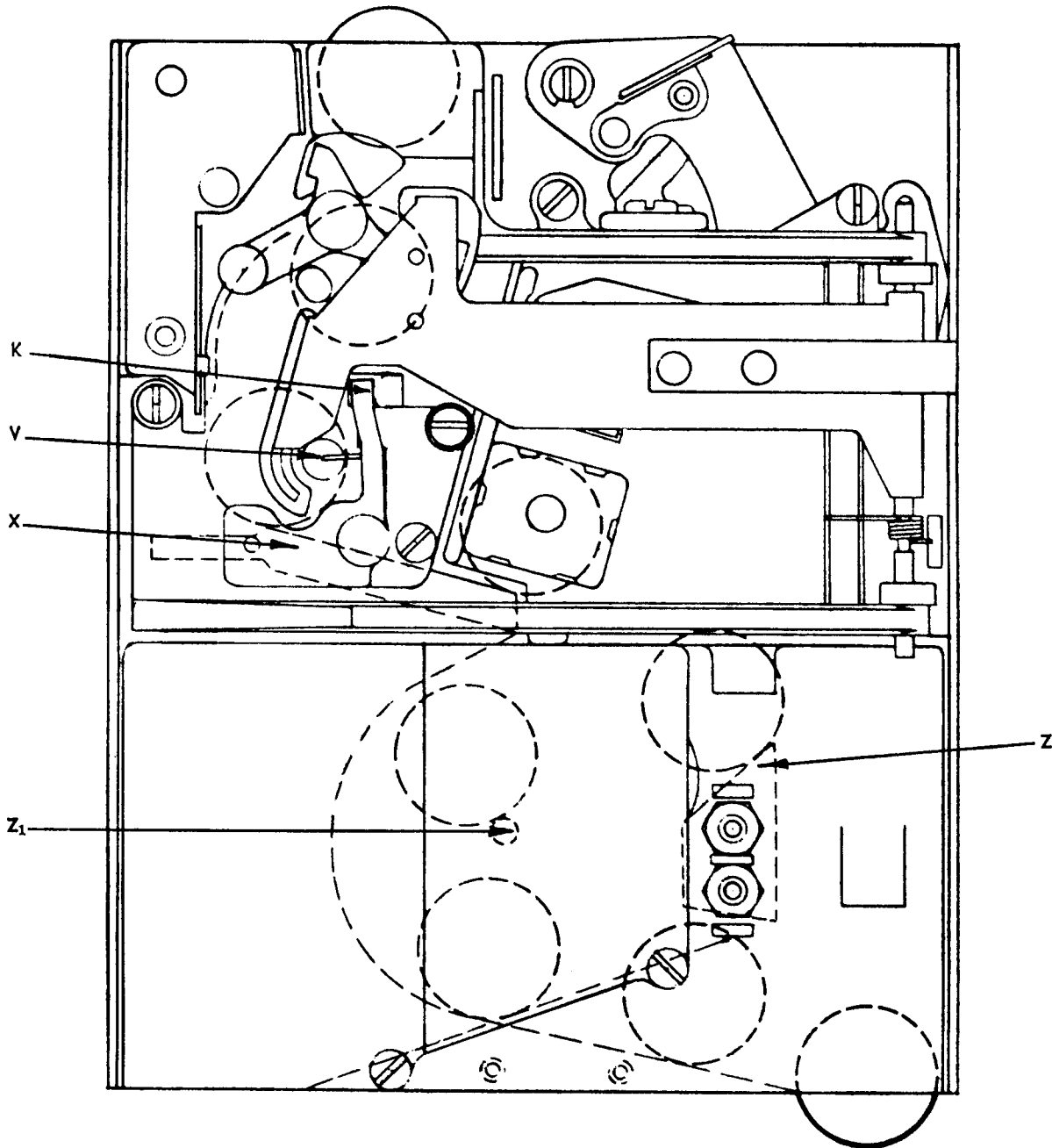

FIG. 8—PATH OF 5c COIN

The 5c coin will pass through the 25c rotary gauge and engage the 5c undersize gauge lever (Item K). If the coin is of the correct diameter, lever K will turn slightly on its pivot and withdraw undersize gauge wire (Item V) from the path of the coin to permit it to drop on the rail (Item X). The genuine 5c coin, having an un-

usually high resistance will roll down rail X at a high rate of speed striking the anvil (Item Z) from which it will rebound with enough force to clear the barrier stud (Item Z1). Thus it is shown that 5c coins are tested for hardness as well as electrical resistance.

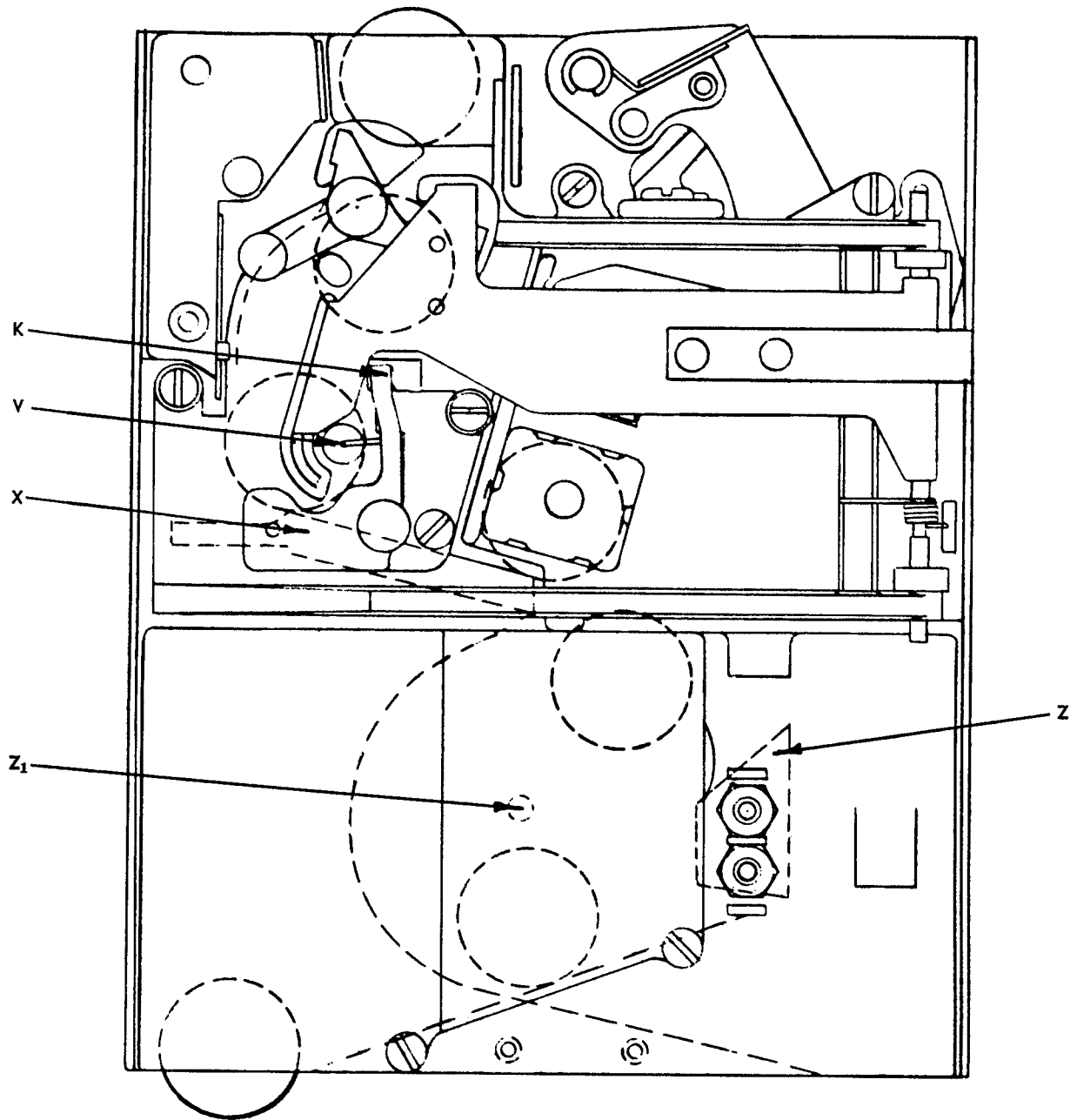

FIG. 9—PATH OF 5c SIZE BRASS, ZINC OR COPPER SLUGS

5c size slugs of brass, copper or zinc all have electrical resistance much lower than the alloy of which nickels are made and as a result will be

slowed down in the magnetic field, this will cause all such spurious coins to strike the anvil too low or miss it entirely and thus be rejected.

REGULAR PERIODIC INSPECTION AND CLEANING

The continued successful operation of the slug rejector depends on the precise speed with which coins move thru the magnetic fields. Anything that retards the free movement of coins thru the runways, as well as improper leveling, are conditions that must be corrected before any change in adjustments is made. If careful inspection indicates that further readjustment is required, we

recommend that Pages 20 to 29 be studied.

Common forms of dirt can be classified as: dust and particles which can be removed with a brush; metal chips which can be removed by wiping with a clean cloth; sticky syrups that are readily dissolved with alcohol; and oily grime which is removable with carbon tetrachloride.

The following four views illustrate recommended procedures in servicing dirty units.

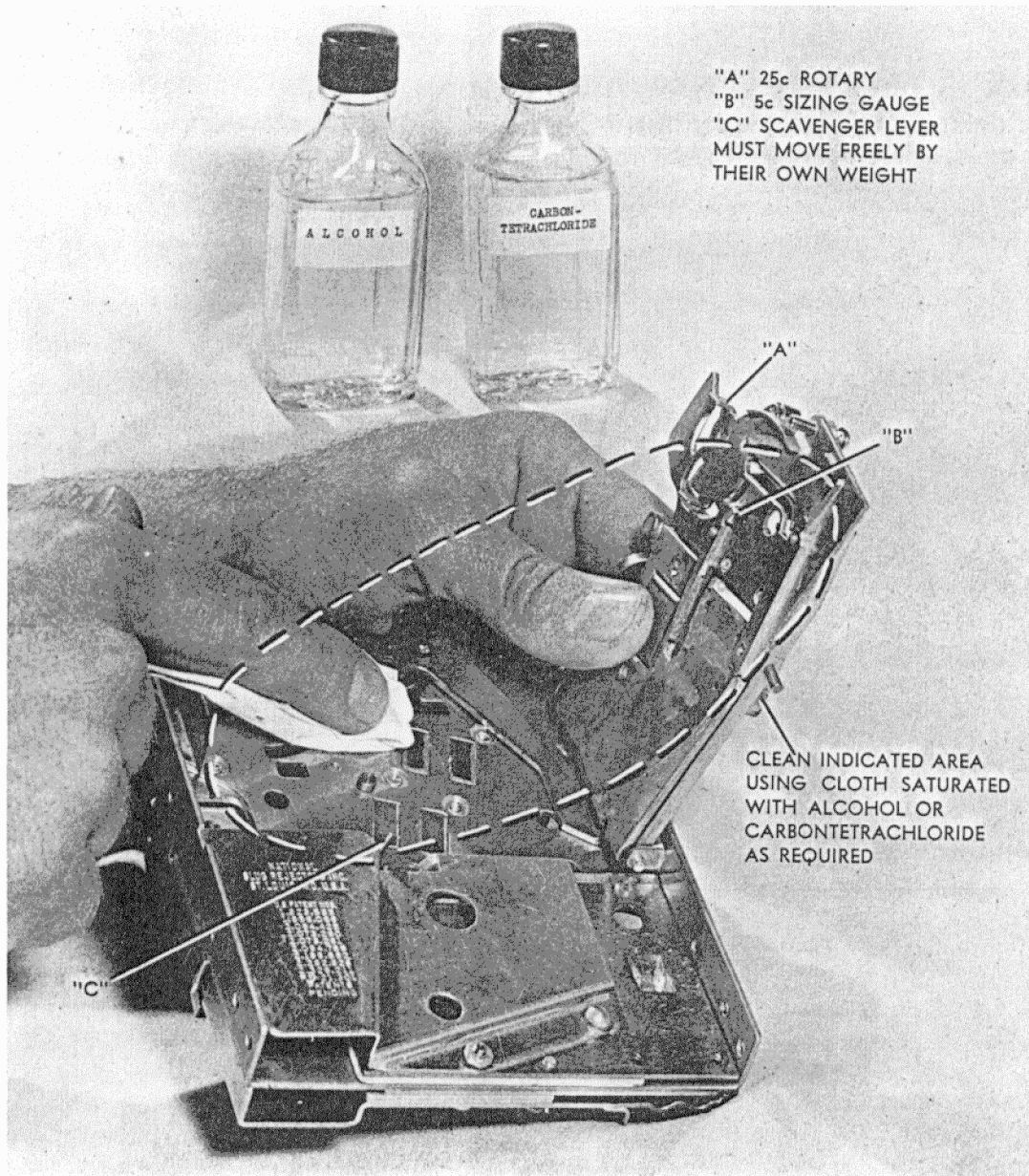

CAUTION! PERMANENT MAGNETS ARE WEAKENED BY REPEATED CONTACT WITH MAGNETIC METALS. DO NOT PLAY WITH MAGNETS.

5-10-25c SLUG REJECTOR

CAUTION!

Do not use highly inflammable solvents, inasmuch as there is an ever present danger of getting burned severely, as well as damaging the

mechanism. Cleaning operations should be conducted in well-ventilated surroundings. Avoid prolonged inhaling of fumes from any solvent.

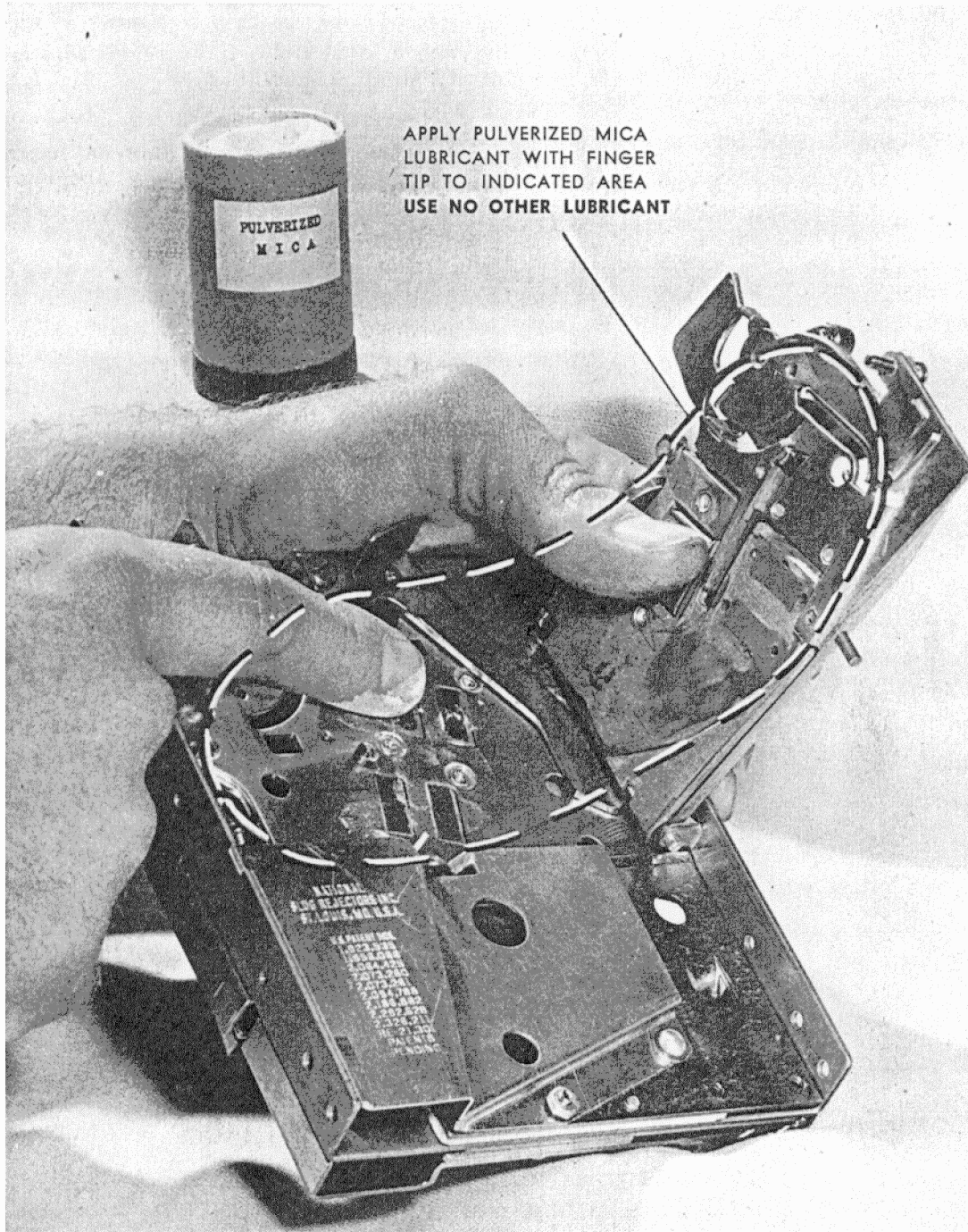

5-10-25c SLUG REJECTOR

When cleaning and adjusting, do not use sharp tools or abrasives of any kind, because incorrect operation of the unit may result.

It is recommended that screw drivers with properly ground bits be used to avoid burring

screw heads. If it becomes necessary to remove screws, be sure to replace them in their respective holes, together with all washers as originally assembled, because a protruding screw end may block a coin path.

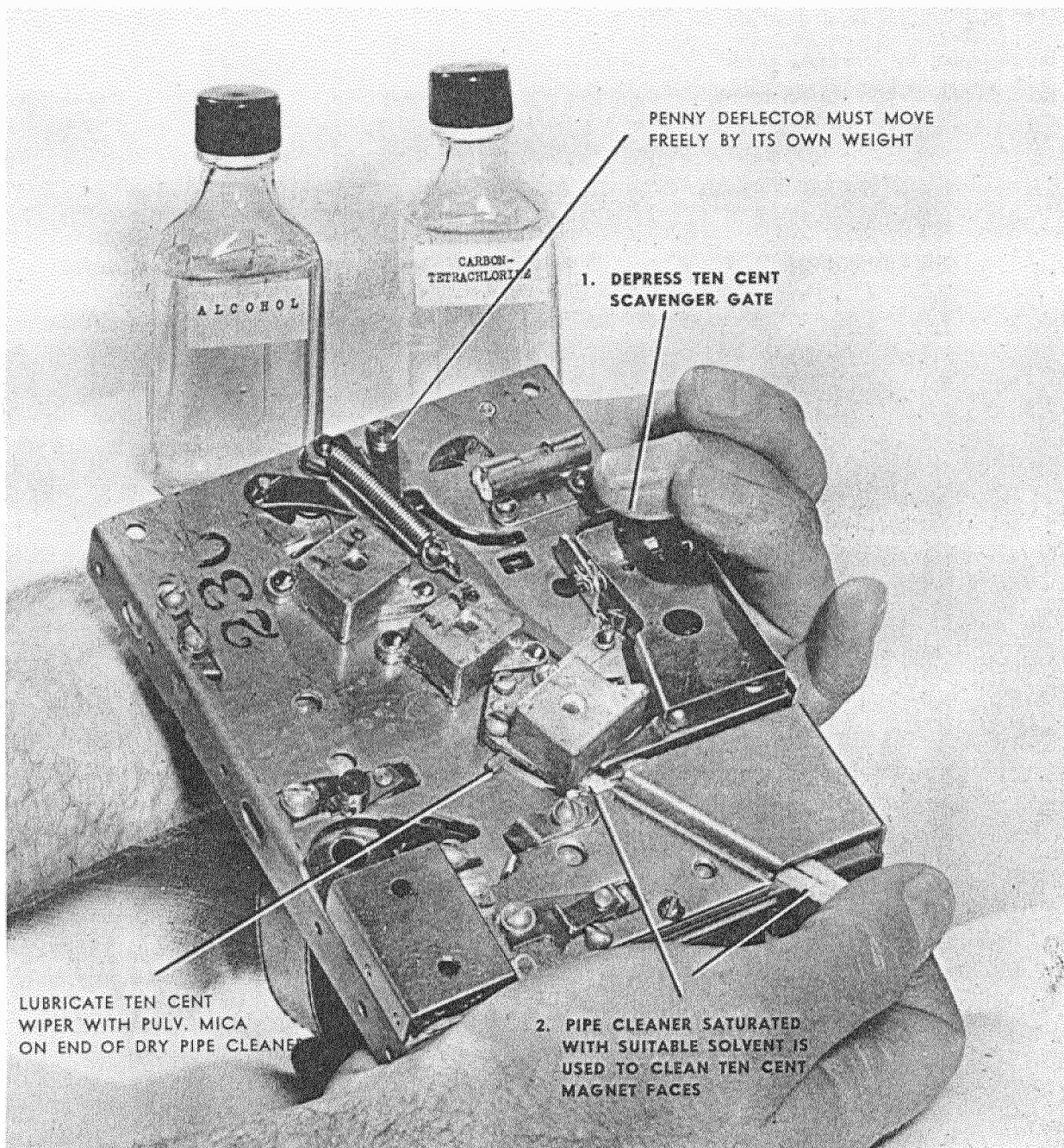

5-10-25c SLUG REJECTOR

LEVELING AND SCAVENGER OPERATION

When the phonograph is in position, edge "x" is perpendicular and at right angle to level in square. If not, loosen points "y" and tilt entire slug rejector assembly to level point, as indicated in square level "b". Tighten points "y" securely.

If slug rejector level does not agree it should be corrected by loosening screws "z", tilted to bring bubble "a" in correct position and holding screws "z" tightened.

The scavenger mechanism must make a full stroke when operated from the outside button to clear certain magnetic coins and slugs. *Maximum allowable gap at point "w" must not exceed 1/32 inch.* When the scavenger button is pushed in as far as it will go, approximately 1/8 inch remains protruding at the end of the stroke.

Corrective adjustments having been made check operation of mechanism by inserting several coins, one at a time.

